

SAMSUNG

SYSTEM AIR CONDITIONER

	INDOOR UNIT	OUTDOOR UNIT
Model :	AC012MNADCH/AA	AC012KXADCH/AA
	AC018MNADCH/AA	AC018JXADCH/AA
	AC024MNADCH/AA	AC024JXADCH/AA
	AC030MNTDCH/AA	AC030JXADCH/AA
	AC036MNTDCH/AA	AC036JXADCH/AA

SERVICE *Manual*

AIR CONDITIONER



AC012/018/024MNADCH



AC030/036MNTDCH



AC012KXADCH



AC018JXADCH



AC024JXADCH
AC030JXADCH



AC036JXADCH

CONTENTS

1. Precautions
2. Product Specifications
3. Disassembly and Reassembly
4. Troubleshooting
5. PCB Diagram
6. Wiring Diagram
7. Reference Sheet

Refer to the service manual in the GSPN(see the rear cover) for the more information.

Contents

1. Precautions	1-1
1-1 Precautions for the Service	1-1
1-2 Precautions related to static electricity and PL	1-1
1-3 Precautions related to product safety	1-2
1-4 Other precautions	1-2
2. Product Specifications	2-1
2-1 The Feature of Product	2-1
2-2 Product Specifications	2-2
2-3 Accessories	2-5
3. Disassembly and Reassembly	3-1
3-1 Indoor Unit	3-2
3-2 Outdoor Unit	3-18
4. Troubleshooting	4-1
4-1 Troubleshooting for indoor unit	4-1
4-2 Troubleshooting for outdoor unit	4-11
4-3 Troubleshooting by symptoms	4-13
4-3-1 Indoor temperature sensor (open/short)	4-13
4-3-2 Indoor heat exchanger temperature sensor (open/short)	4-14
4-3-3 Indoor FAN error	4-15
4-3-4 Communication error after finishing Tracking	4-16
4-3-5 Indoor unit float sensor error	4-17
4-3-6 EEPROM circuit failure	4-18
4-3-7 Outdoor unit is not powered on	4-19
4-4 Troubleshooting by symptoms	4-21
4-4-1 Communication error	4-21
4-4-2 Outdoor temperature sensor error	4-22
4-4-3 Outdoor Coil temperature sensor error	4-24
4-4-4 Outdoor Discharge temperature sensor error	4-26
4-4-5 Outdoor Discharge over temperature error	4-28
4-4-6 Outdoor Fan motor error	4-29
4-4-7 Compressor starting error	4-30
4-4-8 Compressor wire missing error/rotation error	4-31
4-4-9 O.C(Over Current) error	4-32
4-4-10 DC_link voltage sensor error	4-33
4-4-11 DC_link voltage under/over error, Over voltage protection error/PFC over load	4-34

4-4-12 DC_link voltage sensor error	4-35
4-4-13 Current sensor error/Input current sensor error	4-36
4-4-14 Heatsink sensor error/Heatsink over heat	4-37
4-4-15 Comp Vlimit error/Comp current limit error	4-38
4-4-16 EEPROM error/OTP error	4-39
4-4-17 AC zero cross signal error	4-40
4-4-18 Operation condition secession error.....	4-41
4-4-19 Capacity miss match error	4-42
4-4-20 Gas leak error	4-43
5. PCB Diagram	5-1
5-1 Indoor Unit	5-1
5-2 Outdoor Unit	5-4
6. Wiring Diagram	6-1
6-1 Indoor Unit	6-1
6-2 Outdoor Unit	6-2
7. Reference Sheet	7-1
7-1 Index for Model Name.....	7-1
7-2 Refrigerating Cycle Diagram.....	7-2

1. Precautions

1-1 Precautions for the Service

- ◆ **Use the standard parts when replacing the electric parts.**
 - Confirm the model name, rated voltage, rated current of the electric parts.

- ◆ **When repairing the equipment, connection of the harness parts must be firm and solid.**
 - A loose connection may cause noise or other malfunction.

- ◆ **When assembling and disassembling the equipment while it is laid down, lay it on soft cloth.**
 - Otherwise it may scratch the back of the exterior of the product.

- ◆ **Remove dust or dirt completely from the housing block, wiring block and service parts during repair.**
 - This helps prevent the danger of fire caused by tracking or short circuit.

- ◆ **Fasten the valve caps of service valves and charging valves of outdoor unit as much as possible using adjustable wrenches.**

- ◆ **Check the status of the components' assembly after repair service.**
 - The status must be the same as before the repair service.

1-2 Precautions related to static electricity and PL

- ◆ **The PCB power supply block is susceptible to static electricity. Therefore, care must be taken during repair or measuring while the power is on.**
 - Wear insulation gloves for PCB repair or measuring.

- ◆ **Check whether the installation location is at least two meters away from other electronic products such as TV, video, or audio.**
 - Otherwise, the video quality might be degraded or noise might be generated.

- ◆ **Do not let end users repair the products themselves.**
 - Unauthorized disassembly might cause electric shock or fire.

1-3 Precautions related to product safety

- ◆ **Do not pull the power cord and do not touch the power plug or aux power switch with wet hands.**
 - It might cause electric shock or fire.
- ◆ **A damaged power line or power plug must be replaced to prevent danger.**
- ◆ **Do not bend the power cable with excessive force, and do not place a heavy weight on the case as it might damage the cable.**
 - It might cause electric shock or fire.
- ◆ **Do not use multiple electric outlets.**
 - This might cause electric shock or fire.
- ◆ **Connect the ground terminal when necessary.**
 - You must connect the ground terminal if you determine that there is a danger of electric leakage due to moisture or water.
- ◆ **Unplug the power cable or turn off the auxiliary power switch for electric part replacement and repair service.**
 - Otherwise it might cause electric shock.
- ◆ **Instruct end users to separate the batteries from the remote controllers and store them separately when the product is not used for long time.**
 - Otherwise leakage from the dry cell may cause problems with the remote controller.

1-4 Other precautions

- ◆ **The pipes should have no leaks during installation, and the compressor must be stopped before removing connecting pipes for pump down work. Operating the compressor while the service valve is open and coolant pipe is not properly connected may cause explosion or injury due to abnormal high pressure created inside the coolant cycle as the air can be absorbed through the pipe.**
- ◆ **Pump Down work procedure (When uninstalling the product)**
 - Turn on the air conditioner, select cooling operation, and run the compressor for more than three minutes.
 - Release the high pressure and low pressure valve caps.
 - Close the high pressure valve completely using an L-wrench
 - After about two minutes, close the low pressure valve completely.
 - Stop running the air conditioner.
 - Separate the connecting pipe.

2. Product Specifications

2-1 The Feature of Product

◆ **Built-in Cassette Type**

After installed, the air conditioner can be harmonized with a room interior.

◆ **High Performance & Energy Saving**

With the advanced BLDC inverter technology, it makes a room cool with highly energy saving and arises the efficiency of air conditioner.

◆ **Long Ambient Operation(In Low Temperature)**

It can arise the reliability and the capacity of the air conditioner, especially operated in low temperature.

◆ **Eco-friendly Product(Lead-Free, ROHS, WEEE)**

◆ **Easy installation of ultra-lightweight indoor unit**

2-2 Product Specifications

ITEM			AC012MNADCH AC012KXADCH	AC018MNADCH AC018JXADCH
IMAGE	Indoor Unit			
	Outdoor Unit			
	Remote Controller			
Power	Product		1Φ, 220~240V, 50Hz	1Φ, 220~240V, 50Hz
Indoor	L x H x D	mm	750*246*249	896*261*261
Outdoor	L x H x D	mm	790*285*548	880*310*638
Indoor	Product	kg(Net)	7.6	10.6
Outdoor	Product	kg(Net)	36.2	45.0
Capacity	Cooling(STD)	Btu/h	12 000	18 000
	Heating(STD)	Btu/h	14 000	20 000
Power Consumption	Cooling(STD)	W	1220	2160
	Heating(STD)	W	1680	1960
Operation current	Cooling(STD)	A	5.7	9.4
	Heating(STD)	A	7.4	8.5
Noise (Cooling/ Heating)	Indoor unit	In case of strongest air blow	dBA	43/43
	Outdoor unit	In case of strongest air blow	dBA	54/54
Refrigerant (R410A)		g	1050	1300
Connecting Pipe	Liquid	mm	6.35	6.35
	Gas	mm	9.52	12.70
Additional Refrigerant (R410A)		g/m	10	10
Standard		m	7.5	7.5
Extension length(Total)		m	20	30
Extension length(Elevation)		m	15	15
Option Code	Product Option		0100FC-19548C-272328-371708	0100FC-19548E-27343E-3C170D
	Installation Option		020000-100000-200000-300000	020000-100000-200000-300000

ITEM			AC024MNADCH AC024JXADCH	AC030MNTDCH AC030JXADCH
IMAGE	Indoor Unit			
	Outdoor Unit			
	Remote Controller			
Power	Product		1Φ, 220~240V, 50Hz	1Φ, 220~240V, 50Hz
Indoor	L x H x D	mm	1065*294*301	1280*345*253
Outdoor	L x H x D	mm	940*330*998	940*330*998
Indoor	Product	kg(Net)	14.5	18.5
Outdoor	Product	kg(Net)	64.5	70.0
Capacity	Cooling(STD)	Btu/h	24 000	30 000
	Heating(STD)	Btu/h	27 000	32 000
Power Consumption	Cooling(STD)	W	2350	3150
	Heating(STD)	W	2560	3360
Operation current	Cooling(STD)	A	10.4	13.7
	Heating(STD)	A	11.4	14.7
Noise (Cooling/ Heating)	Indoor unit	In case of strongest air blow	dBA	51/51
	Outdoor unit	In case of strongest air blow	dBA	60/60
Refrigerant (R410A)		g	2100	2600
Connecting Pipe	Liquid	mm	6.35	9.52
	Gas	mm	15.88	15.88
Additional Refrigerant (R410A)		g/m	10	22
Standard		m	7.5	7.5
Extension length(Total)		m	50	50
Extension length(Elevation)		m	30	30
Option Code	Product Option		0100FC-19547F-274750-37170D	0110FC-193573-275A64-37770D
	Installation Option		020000-100000-200000-300000	020000-100000-200100-300000

ITEM			AC036MNTDCH AC036JXADCH	
IMAGE	Indoor Unit			
	Outdoor Unit			
	Remote Controller			
Power	Product		1Φ, 220~240V, 50Hz	
Indoor	L x H x D	mm	1280*345*253	
Outdoor	L x H x D	mm	940*330*1210	
Indoor	Product	kg(Net)	18.5	
Outdoor	Product	kg(Net)	88.0	
Capacity	Cooling(STD)		Btu/h	36 000
	Heating(STD)		Btu/h	40 000
Power Consumption	Cooling(STD)		W	3870
	Heating(STD)		W	4120
Operation current	Cooling(STD)		A	16.5
	Heating(STD)		A	17.8
Noise (Cooling/ Heating)	Indoor unit	In case of strongest air blow	dBA	55/55
	Outdoor unit	In case of strongest air blow	dBA	60/60
Refrigerant (R410A)		g	2800	
Connecting Pipe	Liquid	mm	9.52	
	Gas	mm	15.88	
Additional Refrigerant (R410A)		g/m	33	
Standard		m	7.5	
Extension length(Total)		m	75	
Extension length(Elevation)		m	30	
Option Code	Product Option	0110FC-194594-276470-39670D		
	Installation Option	020000-100000-200100-300000		

2-3 Accessories

Item	Description	Code No.	Q'ty	Remark
	Remote Control	DB93-15882S	1	Essential Offer (Indoor Unit)
	Batteries for Remote Control	4301-000121	2	
	USER & INSTALLATION MANUAL	DB68-07119A	1	
	Remote Control Holder	DB61-06087A	1	
	M4 x 16 Tapped Screws	6002-000234	2	
	Cap Screws	DB67-01404B (AC012/018/024MNADCH)	3	
	CARD WARRNATY	DB68-02596B	1	
	Drain Plug	DB67-20011A	1	Essential Offer (Outdoor Unit)
	Rubber Leg	DB67-01533A	4	
	INSTALLATION MANUAL	DB68-06488A	1	





3. Disassembly and Reassembly









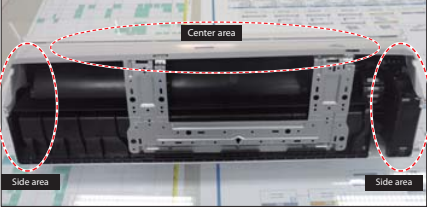

◆ Necessary Tools

Item	Remarks
+SCREW DRIVER	
Adjustable Wrench (8mm, 10mm, 13mm)	
M6, M8 Hex Wrench	

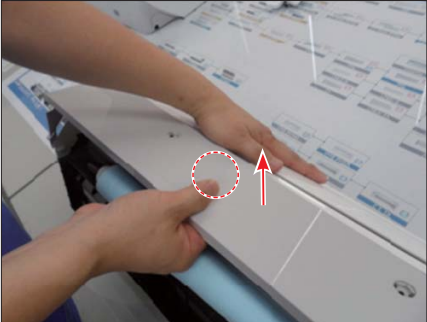
3-1 Indoor unit

◆ AC012MNADCH / AC018MNADCH / AC024MNADCH



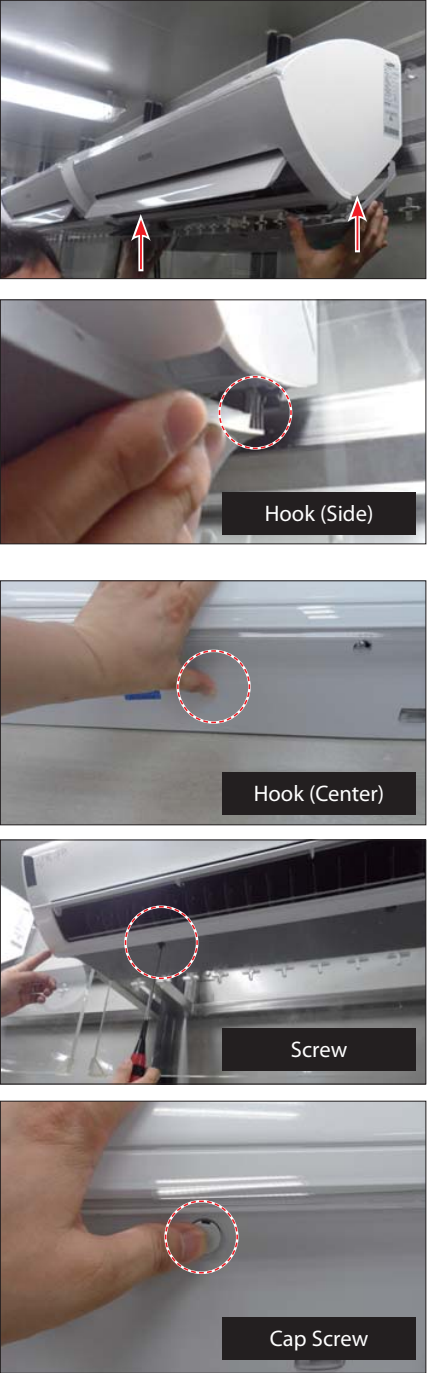

No	Parts	Procedure	Remark
1	PANEL-FRONT	<p>1) Stop the driving of air conditioner and shut off main power supply.</p> <p>2) Detach FILTER PRE from the PANEL FRONT.</p> <p>3) Cover Panel is assembled on bottom of indoor unit as shown in the figure. Remove the Cap Screw as shown on the right side and then remove the screw and separate the Cover Panel.</p>	    

No	Parts	Procedure	Remark						
		<p>4) Cover Panel is fixed to body by Hook in center area and side area.</p>	 <table border="1" data-bbox="948 520 1373 667"> <thead> <tr> <th colspan="2">HOOK</th> </tr> </thead> <tbody> <tr> <td>026/035</td> <td></td> </tr> <tr> <td>052/071</td> <td></td> </tr> </tbody> </table> <p>5) Separate the hook after pushing both end of Cover Panel as shown in the figure. (Watch out for the damage of the hook)</p>  <p>6) Raise front part upward obliquely as shown in the figure and then remove the hooks.</p>  	HOOK		026/035		052/071	
HOOK									
026/035									
052/071									

No	Parts	Procedure	Remark
		<p>⚠ Caution: Assembly of Cover Panel after service end.</p> <ul style="list-style-type: none"> - Reassembly is in the reverse order of the removal. - Piping and drain hose must be careful not to damage and Progress must be done with both hands. 	

No	Parts	Procedure	Remark
		<p>7) To detach the PANEL-FRONT from the main frame, unfasten 2 screws at the bottom. (use + Screw Driver)</p>	 
		<p>8) To detach the COVER-PANEL from the main frame, loosen 4 HOOK Structures. When separate the hook: Use the (-) screw Driver. (-)Screw Driver Insert the hook and then pull the hook as shown on the right side. (Watch out for the damage of the hook)</p>	 

No	Parts	Procedure	Remark
		<p>9) Remove the Panel Frame from the Main Frame as shown on the right side.</p>	



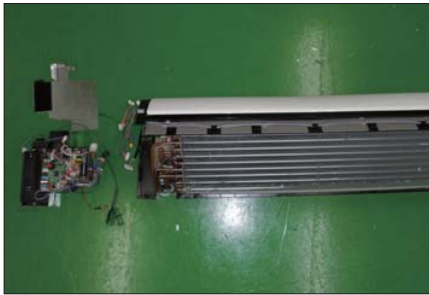
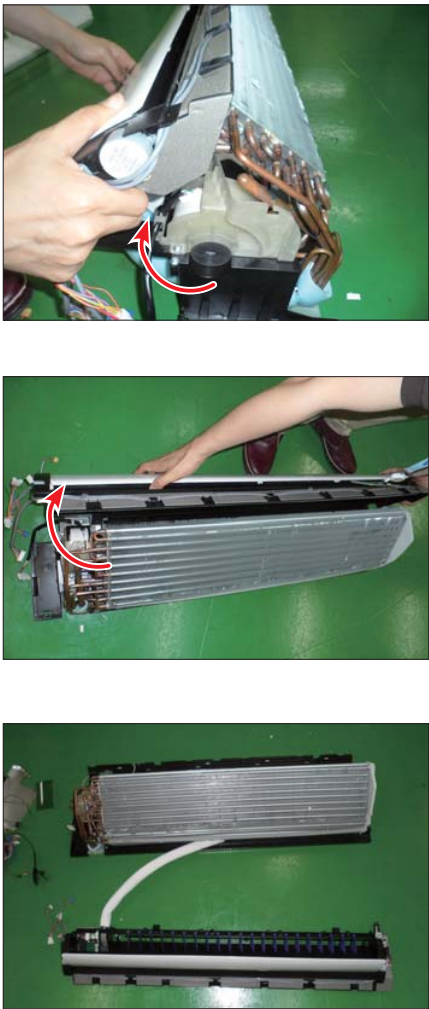

No	Parts	Procedure	Remark
2	CONTORLIN	<p>1) Loosen Sub PBA Wire.</p> <p>⚠ Caution: When you separate the connector, pull pressing the locking button.</p> <p>2) Loosen Stepping Motor, EEV, Display, Sensor, SPI, Fuse Wire.</p> <p>⚠ Caution: When you separate the connector, pull pressing the locking button.</p> <p>3) Loosen Motor, Terminal Wire.</p> <p>⚠ Caution: When you separate the connector, pull pressing the locking button.</p> <p>4) Loosen Earth Wire.</p>	    







No	Parts	Procedure	Remark
5	EVAPORATOR	9) Take off the CASE-CONTROL from the main frame after loosen the remaining connector. ⚠ Caution: When you separate the connector, pull pressing the locking button.	
3	TRAY DRAIN	1) To detach TRAY-DRAIN from the main frame, pull the bottom of the TRAY-DRAIN towards you.	

No	Parts	Procedure	Remark
4	Evaporator	<p>1) Detach the HOLDER PIPE.</p> <p>2) Unfasten the screw at the left side. (use + Screw Driver)</p> <p>3) Unfasten the screw at the right side. (use + Screw Driver)</p> <p>4) To detach Evaporator from the main frame, pull the bottom of the Evaporator towards you.</p>	   

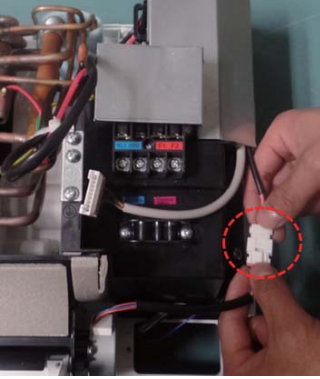

No	Parts	Procedure	Remark
5	FAN MOTOR & CROSS FAN	<p>1) Unfasten the screw. (use + Screw Driver)</p> <p>2) Detach the FAN Motor case.</p> <p>3) Unfasten the screw a little. (use + Screw Driver)</p> <p>4) Pull the CROSS-FAN to the left side.</p>	   

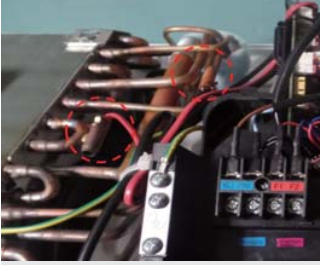
◆ AC030MNTDCH / AC036MNTDCH

No	Parts	Procedure	Remark
1	PANEL-FRONT	<p>1) Stop the driving of air conditioner and shut off main power supply.</p> <p>2) Open the FRONT-GRILLE and pull out from the PANEL-FRONT.</p> <p>3) Detach COVER-TERMINAL from the PANEL FRONT. (use + Screw Driver)</p> <p>4) Loosen connector wire(white) and detach the temperature sensor wire.</p> <p>5) To detach the FRONT-PANELthe main frame, unfasten 2 screw at the bottom.(use + Screw Driver)</p> <p>6) Take off the FRONT-PANEL,lifting up the bottom</p>	    

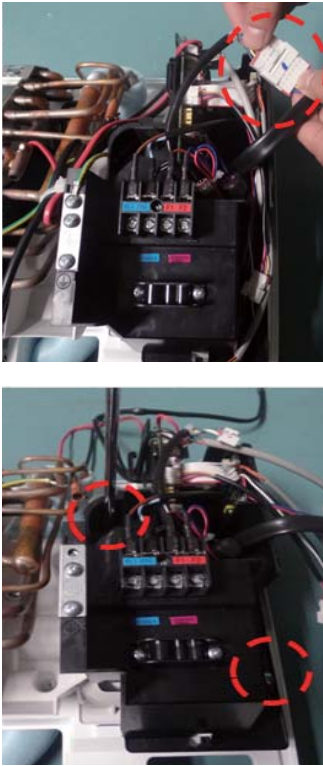
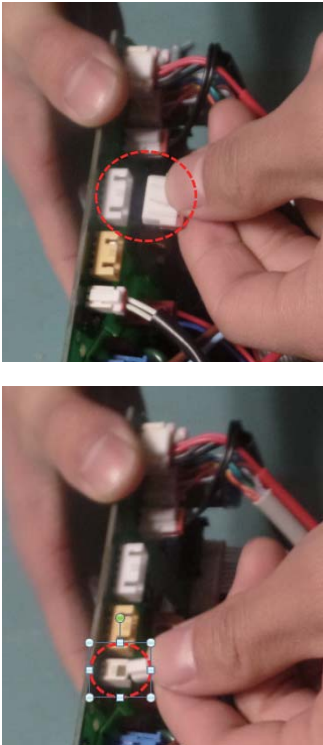

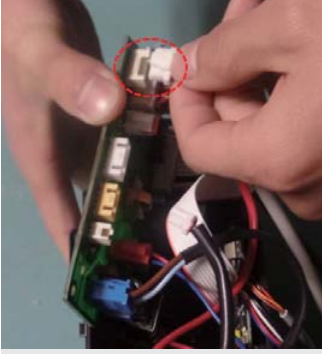

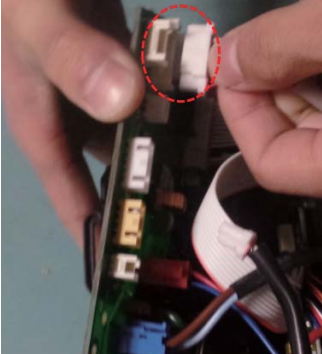
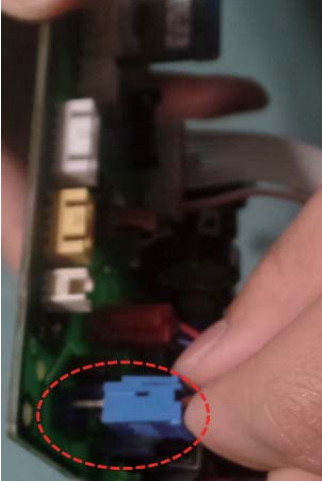
No	Parts	Procedure	Remark
2	TRAY DRAIN	<p>1) Loosen stepping motor wire and detach the hook of main frame.</p> <p>2) To detach TRAY-DRAIN from the main frame, pull the bottom of the TRAY-DRAIN towards you.</p> <p>3) To detach TRAY-DRAIN from the main frame, pull the bottom of the TRAY-DRAIN towards you.</p>	  
3	CONTROL IN	<p>1) Unfasten the earth screw.(use + ScrewDriver)</p> <p>2) Detach the temperature sensor and Humidity sensor.</p> <p>3) Detach the temperature sensor.</p>	  

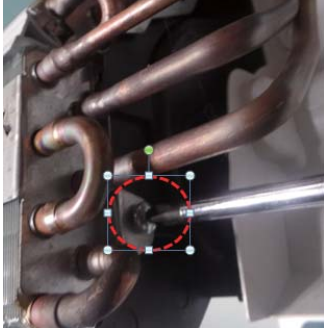
No	Parts	Procedure	Remark
		<p>4) Loosen MOTOR wires(white).</p> <p>5) Take off the CASE-CONTROL from the main frame. (use + Screw Driver)</p>	
4	PBA	<p>1) Loosen the STEP UP/DOWN connector(CN802).</p> <p>⚠ Caution: When you separate the connector, pull pressing the locking button.</p> <p>2) Loosen the FUSE CHK connector (CN140).</p> <p>⚠ Caution: When you separate the connector, pull pressing the locking button.</p>	

No	Parts	Procedure	Remark
		<p>3) Loosen the EVA IN/OUT connector. (CN403)</p> <p>⚠ Caution: When you separate the connector, pull pressing the locking button.</p> <p>4) Loosen the Humidity sensor connector(CN401). ->Option connector.</p> <p>⚠ Caution: The terminal is locking type. So, when you separate terminals, pull pressing the button.</p> <p>5) Loosen the DISPLAY connector. (CN501).</p> <p>⚠ Caution: The terminal is locking type. So, when you separate terminals, pull pressing the button.</p> <p>6) Loosen the POWER connector.</p> <p>⚠ Caution: When you separate the connector, pull pressing the locking button.</p>	   

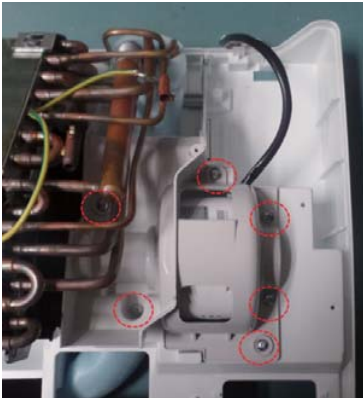



No	Parts	Procedure	Remark
		<p>7) Loosen the COMM wire connector(CN303).</p> <p>⚠ Caution: When you take off the PBA, don't touch the components. Please hold the PBA both side.</p> <p>8) Loosen the Motor connector(CN701).</p> <p>⚠ Caution: When you separate the connector, pull pressing the locking button.</p> <p>9) Take off the main PBA from the ASS'Y Control in.</p> <p>⚠ Caution: When you take off the PBA, don't touch the components. Please hold the PBA both side.</p>	
5	EVAPORATOR	<p>1) Unfasten the screw at the right side. (use + ScrewDriver)</p>	

No	Parts	Procedure	Remark
		2) Unfasten the screw at the left side. (use + ScrewDriver)	
		3) Detach the HOLDER PIPE. (use + Screw Driver)	
		4) Detach the BRACKET-EVAP. (use + Screw Driver)	
		5) Detach the HOLDER EVAP. (use + Screw Driver)	
		6) Loosen 1 fixing earth screw right side. (use + Screw Driver)	



No	Parts	Procedure	Remark
6	FAN MOTOR & CROSS FAN	<p>1) Loosen 6 fixing screws of HOLDER-MOTOR</p> <p>2) unfasten the screw a little. (use + Screw Driver)</p> <p>3) unfasten the screw a little and pull the MOTOR FAN to the right side. (use + Screw Driver)</p> <p>4) Loosen 1 fixing screws of HOLDER-FAN.(use + Screw Driver)</p> <p>5) unfasten the screw a little.(use + Screw Driver)</p>	    

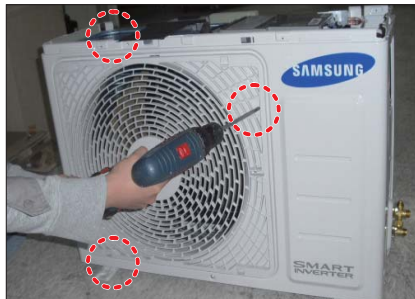

3-2 Outdoor Unit



■ AC012KXADCH

No	Parts	Procedure	Remark
1	common work	<p>1) loosen 1 pcs screw of cover control, and detach it.</p> <p>2) loosen 5 pcs screws on both right and left cabinet side edges and to detach the cover-top</p> <p>3) Loosen 7 screws fixed to disassemble cabi-front , and detach it.</p>	    

No	Parts	Procedure	Remark
	common work	<p>4) loosen 7 screws to disassemble the cabi-right ,and detach it.</p> <p>5) loosen 2 screws to disassemble steel-bar.</p> <p>6) loosen 3 screws to disassemble cabi-left.</p>	   

No	Parts	Procedure	Remark
2	fan&motor	<p>1) loosen 1 screw as indication and detached the fan.</p> <p>2) loosen 4 pcs motor screws and disconnect the wire betweenw assy control out and motor.</p> <p>3) loosen 2 pcs bracket-motor screw and detach it.</p>	  



No	Parts	Procedure	Remark
3	assy control out	<p>1) loosen fixing 1 screw from cover -control</p> <p>2) detach several connections from assy control out, take out assy control out.</p>	
4	Heat exchanger	<p>1) Release the refrigerant at first</p> <p>2) Loosen fixing screw on both side.</p> <p>3) Disassembly the pipes in both inlet and outlet with welding torch.</p> <p>4) detach the heat exchanger.</p>	



No	Parts	Procedure	Remark
5	compressor	1) Disconnect the compressor lead wire . 2) Disassembly the felt comp sound. loosen the 3 bolts at the bottom of	 



■ AC018JXADCH

No	Parts	Procedure	Remark
1	common work	<p>1) loosen 1 pcs screw of cover control, and detach it.</p> <p>2) loosen 5 pcs screws on both right and left cabinet side edges and to detach the cover-top</p> <p>3) Loosen 7 screws fixed to disassemble cabi-front , and detach it.</p>	

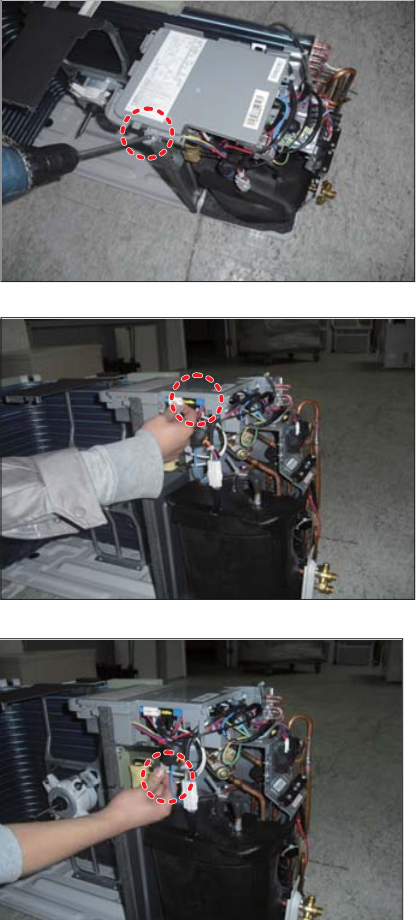

No	Parts	Procedure	Remark
	common work	<p>4) loosen 7 screws to disassemble the cabi-right ,and detach it.</p> <p>5) loosen 2 screws to disassemble steel-bar.</p> <p>6) loosen 3 screws to disassemble cabi-left.</p>	   



No	Parts	Procedure	Remark
2	fan&motor	<p>1) loosen 1 screw as indication and detached the fan.</p> <p>2) loosen 4 pcs motor screws and disconnect the wire between assy control out and motor.</p> <p>3) loosen 2 pcs bracket-motor screw and detach it.</p>	  

No	Parts	Procedure	Remark
3	assy control out	<ol style="list-style-type: none"> 1) loosen fixing 1 screw from cover -control 2) detach several connections from assy control out, take out assy control out. 	
4	Heat exchanger	<ol style="list-style-type: none"> 1) Release the refrigerant at first 2) Loosen fixing screw on both side. 3) disassembly the pipes in both inlet and outlet with welding torch. 4) detach the heat exchanger. 	



No	Parts	Procedure	Remark
5	compressor	<p>1) disconnect the compressor lead wire .</p> <p>2)disassembly the felt comp sound. loosen the 3 bolts at the bottom of</p>	 

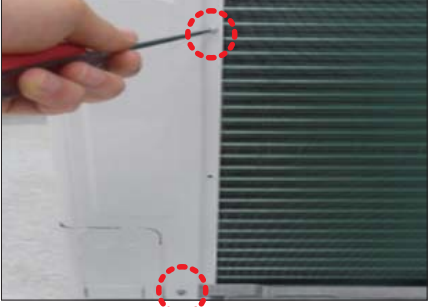
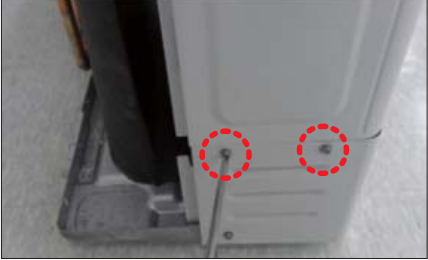

■ AC024JXADCH, AC030JXADCH

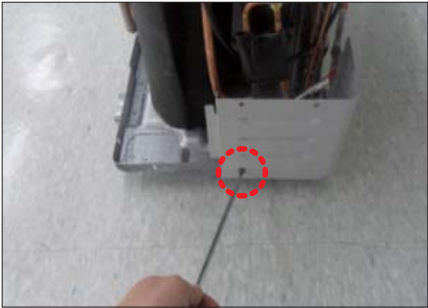
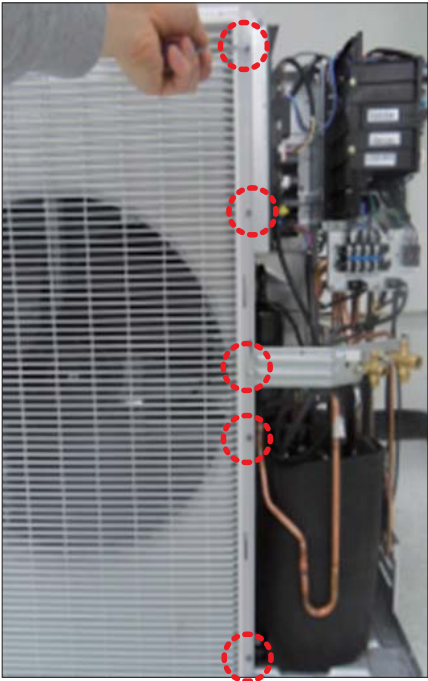
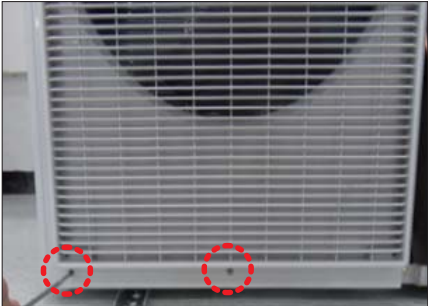
No	Parts	Procedure	Remark
1	Cabi Front RH	<p>⚠ You must turn off the Power before disassembly.</p> <p>1) Unscrew and remove two mounting screw in the Cabinet Front RH. (Use +Screw Driver)</p>	
2	Cabi Top	<p>1) Unscrew and remove 9 screws on each side of the Cabinet-Top. (Use +Screw Driver)</p>	
3	Cabi Install Front	<p>1) Unscrew and remove 1 screw in the Cabinet-Install Front. (Use +Screw Driver)</p>	



No	Parts	Procedure	Remark
4	Guard Cond	1) Pull the sensor from Guard Cond. 2) Unscrew and remove 4 screws in the Guard Cond. (Use +Screw Driver)	 
5	Cabi Back RH	1) Pull the sensor from Cabi Back RH. 2) Unscrew and remove 4 screws on each side of the Cabinet Back RH. (Use +Screw Driver)	  

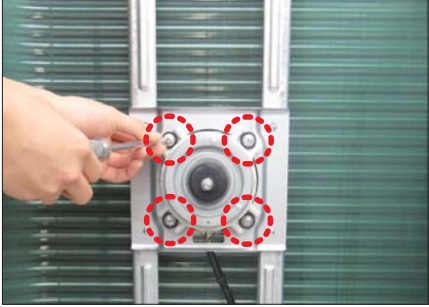

No	Parts	Procedure	Remark
6	Cabi Install Back	1) Unscrew and remove 1 screw in the Cabinet-Install Back. (Use +Screw Driver)	
7	Cabi Front LF	1) Unscrew and remove 10 screws in the Cabinet-Front LF. (Use +Screw Driver)	 

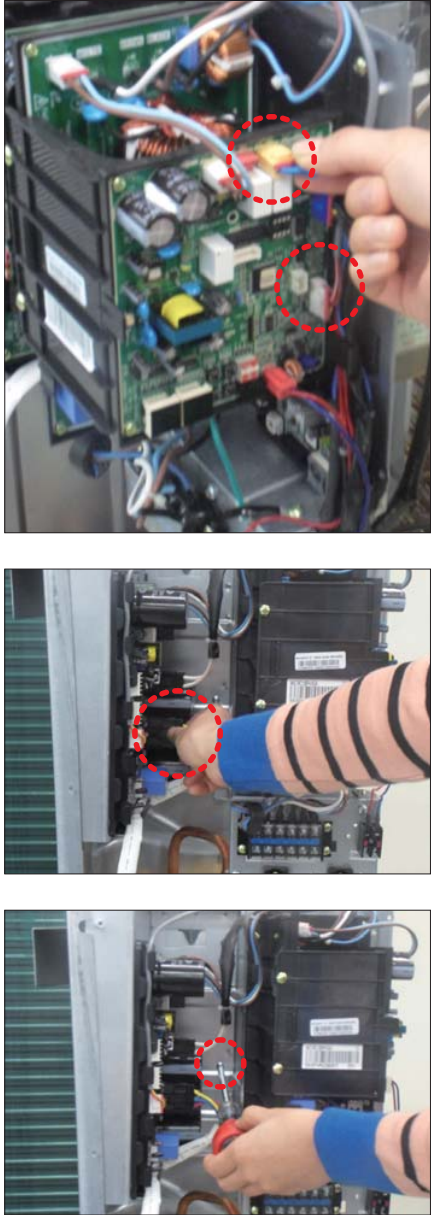
No	Parts	Procedure	Remark
			
8	Fan	1) Turn 2 mounting nuts as shown in the picture and remove it. (Use Adjustable Wrench)	

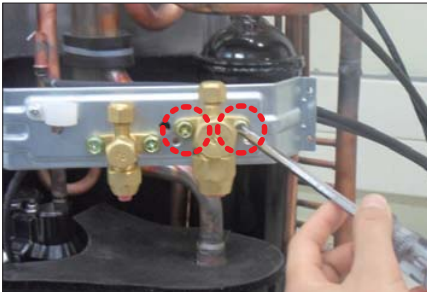
No	Parts	Procedure	Remark
9	Motor	<ol style="list-style-type: none"> 1) Separate the Fan Propeller. 2) Unscrew and remove the 8 Motor mounting screws. (Use +Screw Driver) 3) Disconnect the Motor wire From Ass'y Control Out. 	 
10	Bracket Motor	<ol style="list-style-type: none"> 1) Unscrew and remove 2 mounting screws in Bracket Motor. (Use +Screw Driver) 	



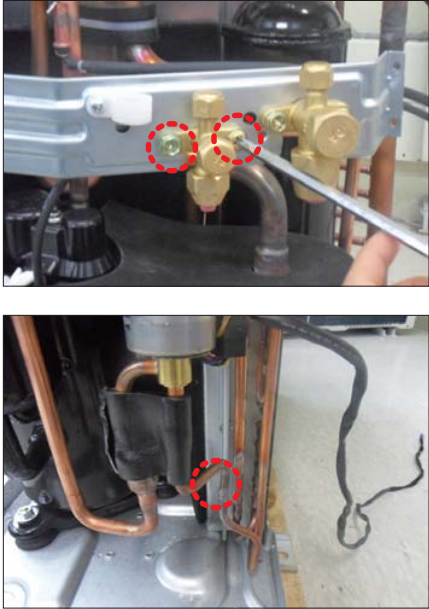

No	Parts	Procedure	Remark
11	Control Out	<p>1) Disconnect 4 Connecters From Ass'y Control Out.</p> <p>2) Unscrew and remove 1 mounting screw in Control Out. (Use +Screw Driver)</p> <p>3) Separate Ass'y Control Out.</p>	 <p>The 'Remark' column contains three photographs illustrating the procedure. The top photograph shows a hand disconnecting four connectors from a green printed circuit board (PCB), with red dashed circles highlighting each connector. The middle photograph shows a hand using a screwdriver to unscrew a mounting screw from the Control Out assembly, with a red dashed circle highlighting the screw. The bottom photograph shows the Control Out assembly being separated from the main unit, with a red dashed circle highlighting the assembly.</p>

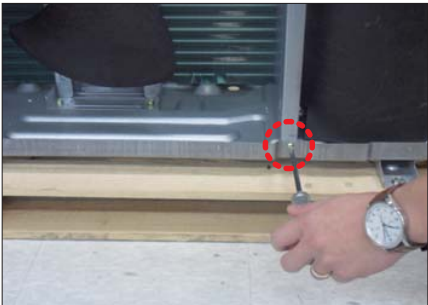
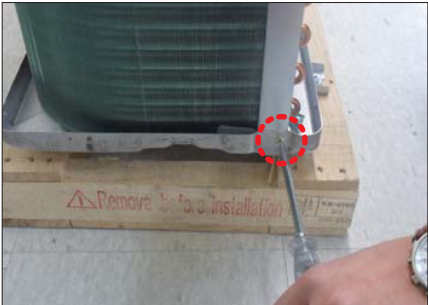
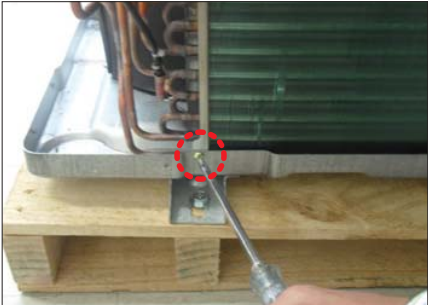



No	Parts	Procedure	Remark
12	Ass'y 4way Valve	<ol style="list-style-type: none">1) Purge the Coolant first.2) Unscrew and remove 2 mounting screws in muffler.3) Unscrew and remove 2 mounting screws in Service Valve. (Use +Screw Driver) <ol style="list-style-type: none">4) Separate the pipe from the Entrance/Exit using a welder. <p style="color: red;">⚠ When removing the compressor, Heat Exchanger, and Pipe, purge the Coolant inside the Compressor completely and remove the pipe with a welding flame.</p>	   

No	Parts	Procedure	Remark
13	Assy EEV Valve	<p>1) Unscrew and remove 2 mounting screws in Service Valve. (Use +Screw Driver)</p> <p>2) Separate the pipe from the Entrance/Exit using a welder.</p>	
14	Compressor	<p>1) Unscrew and remove 1 mounting nut in Cover Terminal. (Use Adjustable Wrench)</p> <p>2) Separate the Compressor Felt Sound.</p>	



No	Parts	Procedure	Remark
		<p>3) As shown in the picture, unscrew and remove 3 mounting screws from the bottom. (Use Adjustable Wrench)</p>	
15	Cond Out	<p>1) Unscrew and remove 3 screws on each side of the Assy Cond Out. (Use +Screw Driver)</p> <p>2) Separate the Compressor Felt Sound.</p>	  

■ AC036JXADCH

No	Parts	Procedure	Remark
1	Cabi Front RH	<p>⚠ You must turn off the Power before disassembly.</p> <p>1) Unscrew and remove two mounting screw in the Cabinet Front RH. (Use +Screw Driver)</p>	
2	Cabi Top	<p>1) Unscrew and remove 9 screws on each side of the Cabinet-Top. (Use +Screw Driver)</p>	
3	Cabi Install Front	<p>1) Unscrew and remove 1 screw in the Cabinet-Install Front. (Use +Screw Driver)</p>	
4	Guard Cond	<p>1) Pull the sensor from Guard Cond.</p> <p>2) Unscrew and remove 4 screws in the Guard Cond. (Use +Screw Driver)</p>	

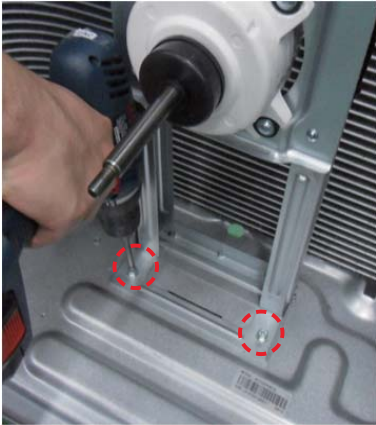
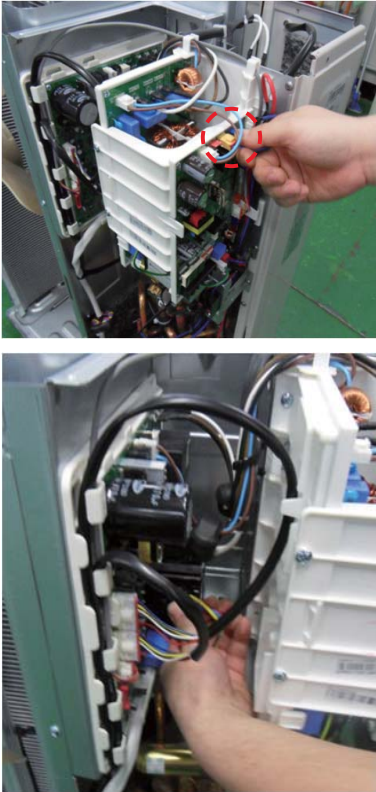
No	Parts	Procedure	Remark
5	Cabi Back RH	1) Pull the sensor from Cabi Back RH. 2) Unscrew and remove 4 screws on each side of the Cabinet Back RH. (Use +Screw Driver)	
6	Cabi Install Back	1) Unscrew and remove 1 screw in the Cabinet-Install Back. (Use +Screw Driver)	
7	Cabi Front LF	1) Unscrew and remove 10 screws in the Cabinet-Front LF. (Use +Screw Driver)	
8	Fan	1) Turn 2 mounting nuts as shown in the picture and remove it. (Use Adjustable Wrench)	

No	Parts	Procedure	Remark
9	Motor	<ol style="list-style-type: none"> 1) Separate the Fan Propeller. 2) Unscrew and remove the 8 Motor mounting screws. (Use +Screw Driver) 3) Disconnect the Motor wire From Ass'y Control Out. 	
10	Bracket Motor	<ol style="list-style-type: none"> 1) Unscrew and remove 2 mounting screws in Bracket Motor. (Use +Screw Driver) 	
11	Control Out	<ol style="list-style-type: none"> 1) Disconnect 4 Connecters From Ass'y Control Out. 2) Unscrew and remove 1 mounting screw in Control Out. (Use +Screw Driver) 3) Separate Ass'y Control Out. 	

No	Parts	Procedure	Remark
12	Assy 4way Valve	<p>1) Purge the Coolant first.</p> <p>2) Unscrew and remove 2 mounting screws in Service Valve. (Use +Screw Driver)</p> <p>3) Separate the pipe from the Entrance/Exit using a welder.</p> <p>⚠ When removing the compressor, Heat Exchanger, and Pipe, purge the Coolant inside the Compressor completely and remove the pipe with a welding flame.</p>	
13	Assy EEV Valve	<p>1) Unscrew and remove 2 mounting screws in Service Valve. (Use +Screw Driver)</p> <p>2) Separate the pipe from the Entrance/Exit using a welder.</p>	

4. Troubleshooting

You cannot set both of the indoor unit addresses and the installation options in a batch: set both of them respectively.

4-1-1 Common steps for setting the addresses and options

MR-EC00 and MR-EH00 remote controls

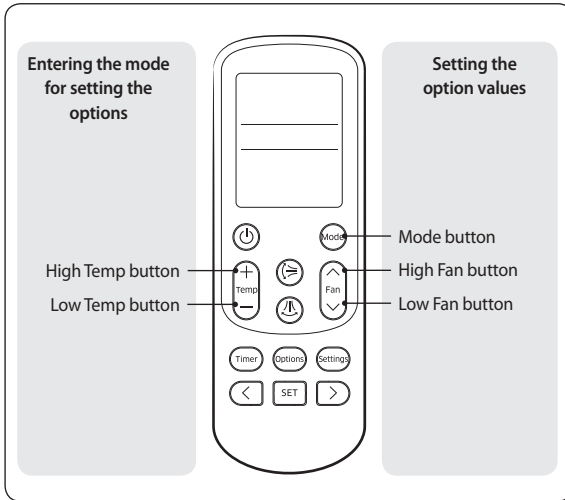

NOTE

- The remote control display and buttons may vary depending on the model.
- Enter the mode for setting the options:
 - Remove the batteries from the remote control, and then insert them again.
 - While holding down the (High Temp) and (Low Temp) buttons simultaneously, insert the batteries into the remote control.
 - Make sure that you are entered to the mode for setting the options:

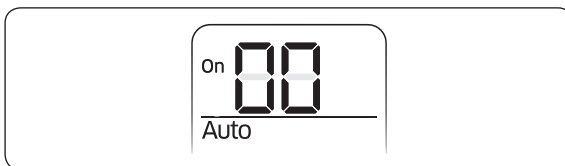

- Set the option values.















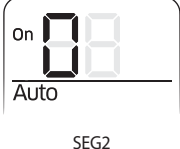
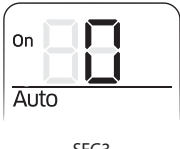

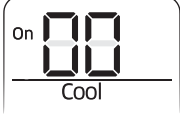
CAUTION



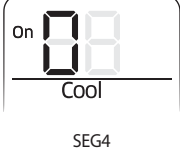
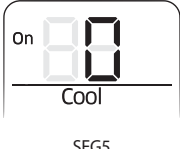





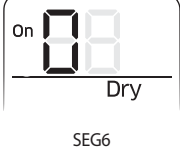
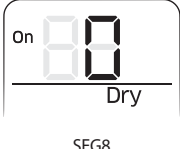











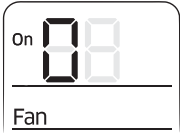
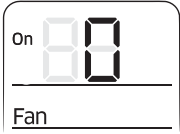

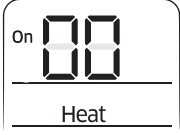

- The total number of available options are 24: SEG1 to SEG24.
- Because SEG1, SEG7, SEG13, and SEG19 are the page options used by the previous remote control models, the modes to set values for these options are skipped automatically.
- Set a 2-digit value for each option pair in the following order: SEG2 and SEG3 → SEG4 and SEG5 → SEG6 and SEG8 → SEG9 and SEG10 → SEG11 and SEG12 → SEG14 and SEG15 → SEG16 and SEG17 → SEG18 and SEG20 → SEG21 and SEG22 → SEG23 and SEG24





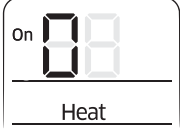
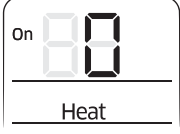

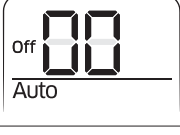

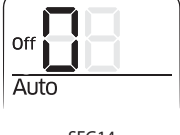





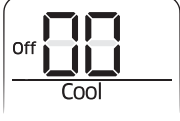

SEG1	SEG2	SEG3	SEG4	SEG5	SEG6
0	X	X	X	X	X
SEG7	SEG8	SEG9	SEG10	SEG11	SEG12
1	X	X	X	X	X
SEG13	SEG14	SEG15	SEG16	SEG17	SEG18
2	X	X	X	X	X
SEG19	SEG20	SEG21	SEG22	SEG23	SEG24
3	X	X	X	X	X

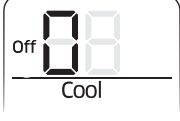
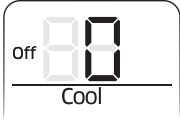





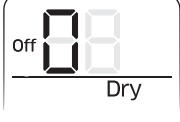

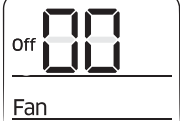

On (SEG1 to SEG12)	Off (SEG13 to SEG24)

Take the steps presented in the following table:

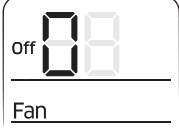
Steps	Remote control display
<p>1 Set the SEG2 and SEG3 values:</p> <p>a Set the SEG2 value by pressing the  (Low Fan) button repeatedly until the value you want to set appears on the remote control display.</p> <p>b Set the SEG3 value by pressing the  (High Fan) button repeatedly until the value you want to set appears on the remote control display.</p> <p>When you press the  (Low Fan) or  (High Fan) button, values appear in the following order: $\square \rightarrow \text{H} \rightarrow \dots \text{E} \rightarrow \text{F}$</p>	 <p style="text-align: center;">SEG2</p>  <p style="text-align: center;">SEG3</p>
<p>2 Press the  (Mode) button. Cool and On appear on the remote control display.</p>	
<p>3 Set the SEG4 and SEG5 values:</p> <p>a Set the SEG4 value by pressing the  (Low Fan) button repeatedly until the value you want to set appears on the remote control display.</p> <p>b Set the SEG5 value by pressing the  (High Fan) button repeatedly until the value you want to set appears on the remote control display.</p> <p>When you press the  (Low Fan) or  (High Fan) button, values appear in the following order: $\square \rightarrow \text{H} \rightarrow \dots \text{E} \rightarrow \text{F}$</p>	 <p style="text-align: center;">SEG4</p>  <p style="text-align: center;">SEG5</p>
<p>4 Press the  (Mode) button. Dry and On appear on the remote control display.</p>	
<p>5 Set the SEG6 and SEG8 values:</p> <p>a Set the SEG6 value by pressing the  (Low Fan) button repeatedly until the value you want to set appears on the remote control display.</p> <p>b Set the SEG8 value by pressing the  (High Fan) button repeatedly until the value you want to set appears on the remote control display.</p> <p>When you press the  (Low Fan) or  (High Fan) button, values appear in the following order: $\square \rightarrow \text{H} \rightarrow \dots \text{E} \rightarrow \text{F}$</p>	 <p style="text-align: center;">SEG6</p>  <p style="text-align: center;">SEG8</p>

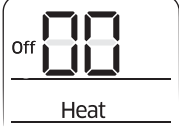
Steps	Remote control display
<p>6 Press the  (Mode) button. Fan and On appear on the remote control display.</p>	
<p>7 Set the SEG9 and SEG10 values:</p> <p>a Set the SEG9 value by pressing the  (Low Fan) button repeatedly until the value you want to set appears on the remote control display.</p> <p>b Set the SEG10 value by pressing the  (High Fan) button repeatedly until the value you want to set appears on the remote control display.</p> <p>When you press the  (Low Fan) or  (High Fan) button, values appear in the following order:  →  → ...  → </p>	 <p style="text-align: center;">SEG9</p>  <p style="text-align: center;">SEG10</p>
<p>8 Press the  (Mode) button. Heat and On appear on the remote control display.</p>	
<p>9 Set the SEG11 and SEG12 values:</p> <p>a Set the SEG11 value by pressing the  (Low Fan) button repeatedly until the value you want to set appears on the remote control display.</p> <p>b Set the SEG12 value by pressing the  (High Fan) button repeatedly until the value you want to set appears on the remote control display.</p> <p>When you press the  (Low Fan) or  (High Fan) button, values appear in the following order:  →  → ...  → </p>	 <p style="text-align: center;">SEG11</p>  <p style="text-align: center;">SEG12</p>
<p>10 Press the  (Mode) button. Auto and Off appear on the remote control display.</p>	
<p>11 Set the SEG14 and SEG15 values:</p> <p>a Set the SEG14 value by pressing the  (Low Fan) button repeatedly until the value you want to set appears on the remote control display.</p>	 <p style="text-align: center;">SEG14</p>

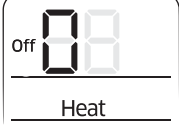
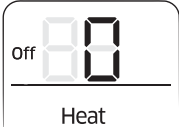

Steps	Remote control display
<p>b Set the SEG15 value by pressing the  (High Fan) button repeatedly until the value you want to set appears on the remote control display.</p> <p>When you press the  (Low Fan) or  (High Fan) button, values appear in the following order: 0 → 1 → ... E → F</p>	 <p>SEG15</p>
<p>1 Press the  (Mode) button. Cool and Off appear on the remote control display.</p>	
<p>2 Set the SEG16 and SEG17 values:</p> <p>a Set the SEG16 value by pressing the  (Low Fan) button repeatedly until the value you want to set appears on the remote control display.</p> <p>b Set the SEG17 value by pressing the  (High Fan) button repeatedly until the value you want to set appears on the remote control display.</p> <p>When you press the  (Low Fan) or  (High Fan) button, values appear in the following order: 0 → 1 → ... E → F</p>	 <p>SEG16</p>  <p>SEG17</p>
<p>3 Press the  (Mode) button. Dry and Off appear on the remote control display.</p>	
<p>4 Set the SEG18 and SEG20 values:</p> <p>a Set the SEG18 value by pressing the  (Low Fan) button repeatedly until the value you want to set appears on the remote control display.</p> <p>b Set the SEG20 value by pressing the  (High Fan) button repeatedly until the value you want to set appears on the remote control display.</p> <p>When you press the  (Low Fan) or  (High Fan) button, values appear in the following order: 0 → 1 → ... E → F</p>	 <p>SEG18</p>  <p>SEG20</p>
<p>5 Press the  (Mode) button. Fan and Off appear on the remote control display.</p>	

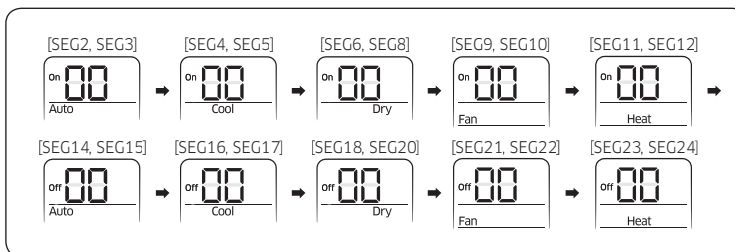

Steps	Remote control display
<p>6 Set the SEG21 and SEG22 values:</p> <p>a Set the SEG21 value by pressing the  (Low Fan) button repeatedly until the value you want to set appears on the remote control display.</p> <p>b Set the SEG22 value by pressing the  (High Fan) button repeatedly until the value you want to set appears on the remote control display.</p> <p>When you press the  (Low Fan) or  (High Fan) button, values appear in the following order: 0 → 1 → ... E → F</p>	 <p style="text-align: center;">SEG21</p>  <p style="text-align: center;">SEG22</p>
<p>7 Press the  (Mode) button. Heat and Off appear on the remote control display.</p>	
<p>8 Set the SEG23 and SEG24 values:</p> <p>a Set the SEG23 value by pressing the  (Low Fan) button repeatedly until the value you want to set appears on the remote control display.</p> <p>b Set the SEG24 value by pressing the  (High Fan) button repeatedly until the value you want to set appears on the remote control display.</p> <p>When you press the  (Low Fan) or  (High Fan) button, values appear in the following order: 0 → 1 → ... E → F</p>	 <p style="text-align: center;">SEG23</p>  <p style="text-align: center;">SEG24</p>

3 Check whether the option values that you have set are correct by pressing the  (Mode) button repeatedly



4 Save the option values into the indoor unit:

Point the remote control to the remote control sensor on the indoor unit and then press the  (Power) button on the remote control twice. Make sure that this command is received by the indoor unit. When it is successfully received, you can hear a short sound from the indoor unit. If the command is not received, press the  (Power) button again.

- 1 Check whether the air conditioner operates in accordance with the option values you have set:
 - a Reset the indoor or outdoor unit.
 - Indoor unit : Press the  (Set) and  (Low Fan) buttons on the remote control simultaneously for 4 seconds.
 - Outdoor unit : Press the K3 button.
 - b Remove the batteries from the remote control, insert them again, and then press the  (Power) button on the remote control.

4-1-2 Setting the indoor unit addresses

Option No. for an indoor unit address: 0AXXXX-1XXXXX-2XXXXX-3XXXXX

Before installing an indoor unit, be sure to set an address for the indoor unit by taking the following steps:

- 1 Make sure that the power is supplied to the indoor unit. If the indoor unit is not plugged in, it must include a power supply.

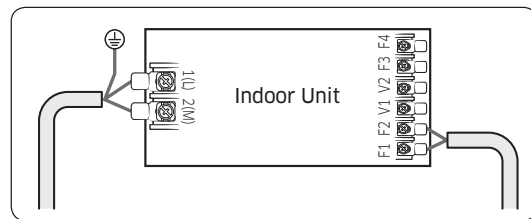

- 2 Set an address for each indoor unit using the remote control, according to your air conditioning system plan, by referring to the following table and by following the steps in **Common steps for setting the addresses and options** on page <?>.
 - The indoor unit addresses (main and RMC addresses) are set to 0A0000-100000-200000-300000 by default.
 - If indoor units and outdoor units match 1:1, you don't need to set the main address because it is automatically set by the outdoor unit.
 - If you are using on or off controller, set RMC address.

Option	SEG1		SEG2		SEG3		SEG4	SEG5		SEG6	
Function	Page		Mode		Setting main address		Reserved	Reserved		Indoor unit number	
Indication and details	Indication	Details	Indication	Details	Indication	Details				Indication	Details
	0		A		0	No main address				0 to 9	Units digit
					1	Main address setting mode					
Option	SEG7		SEG8		SEG9		SEG10	SEG11		SEG12	
Function	Page		Reserved		Setting RMC address		Reserved	Group channel (x16)		Group address	
Indication and details	Indication	Details			Indication	Details		Indication	Details	Indication	Details
	1				0	No RMC address		RMC1	0 to 2	RMC2	0 to F
			1	RMC address setting mode							

⚠ CAUTION

- The main address must be set to a value in the range 0 to 14. If you set other values, communication error will occur.
- If any of SEG5 and SEG6 is set to a value in the range A to F, the main address of the indoor unit does not change.
- If SEG3 is set to 0, the indoor unit maintains the existing main address even if SEG6 is set to a new value.
- If SEG9 is set 0, the indoor unit maintains the existing RMC address even if SEG11 and SET12 are set to new values.

4-1-3 Setting the installation options in a batch

Option No. for an indoor unit address: 02XXXX-1XXXX-2XXXX-3XXXX

- 1 Make sure that the power is supplied to the indoor unit. If the indoor unit is not plugged in, it must include a power supply.

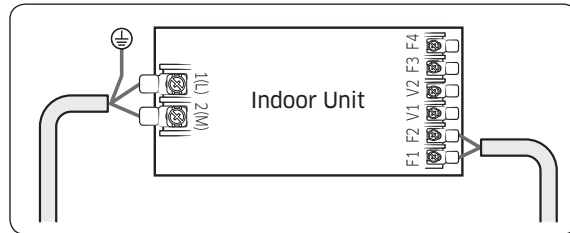

- 2 Set the installation options of indoor units, by referring to the following table and by following the steps in **Common steps for setting the addresses and options** on page <?>.
- The installation options of indoor units are set to 020000-100000-200000-300000 by default.
 - The SEG20 option, Individual control with remote control, allows you to control multiple indoor units individually by using the remote control.

Option	SEG1		SEG2		SEG3	SEG4		SEG5		SEG6	
Function	Page		Mode		Reserved	Use of external temperature sensor		Use of central control		Compensation of the fan RPM	
Indication and details	Indication	Details	Indication	Details		Indication	Details	Indication	Details	Indication	Details
	0		2				0	Disuse	0	Disuse	0
										1	High-ceiling mode (recessed installation)
										4	Disuse (exposed installation)
						1	Use	1	Use	5	High-ceiling mode (exposed installation)

Option	SEG7		SEG8		SEG9		SEG10		SEG11		SEG12	
Function	Page		Use of drain pump									
Indication and details	Indication	Details	Indication	Details	Reserved		Reserved		Reserved		Reserved	
	1		0	Disuse								
			1	Use								
			2	Use with 3 minute delay								
Option	SEG13		SEG14		SEG15		SEG16		SEG17		SEG18	
Function	Page		Use of external control		Setting the output of external control		S-Plasma ion		Buzzer control		Maximum filter usage time	
Indication and details	Indication	Details	Indication	Details	Indication	Details	Indication	Details	Indication	Details	Indication	Details
	2		0	Disuse	0	Thermo on	0	Disuse	0	Use of buzzer	2	1000 hours
			1	On/Off control								
			2	Off control								
			3	Window on/off control								
	2		4	Disuse	1	Operation on	1	Use	1	Disuse of buzzer	6	2000 hours
			5	On/Off control								
			6	Off control								
			7	Window on/off control								
	Option	SEG19		SEG20		SEG21		SEG22		SEG23		SEG24
Function	Page		Individual control with remote control		Heating setting compensation						Cycle time of Swing	
Indication and details	Indication	Details	Indication	Details	Indication	Details	Reserved		Reserved		Indication	Details
	3		0 or 1	Indoor 1	0	Default					0	34 seconds (default)
			2	Indoor 2	1	2°C					1	30 seconds
			3	Indoor 3	2	5°C					2	38 seconds
			4	Indoor 4								

- Even if you set the Use of drain pump (SEG8) option to 0, it is automatically set to 2 (the drain pump is used with 3 minute delay).
- If you set the Maximum filter usage time (SEG18) option to a value other than 2 and 6, it is automatically set to 2 (1000 hours).
- If you set the Individual control with remote control (SEG20) option to a value other than 0 to 4, it is automatically set to 0 (Indoor 1).
- Default value of Heating setting compensation (SEG21) is 5°C for 360 cassette model.

* Level control: The centralized controller can limit the functions and inputs of connected products with this function enabled. (Example: Operation mode limit (Cooling only/Heating only/No limitation), Heating temperature upper limit, Cooling temperature lower limit)
To enable 'Level control' when applying the DPM with the centralized controller, appoint the master (Set 'Use of external control [SEG14] option to 4 or higher).

Example: When installing DPM (1 Outdoor unit with 4 indoor units)

Condition		SEG14 Setting				Result
External control	Level control	Indoor 1	Indoor 2	Indoor 3	Indoor 4	
Default		Not set (0)				Slave (All)
Disuse	Use	4	Not set (0)	Not set (0)	Not set (0)	Master (Indoor 1), Slave (Indoor 2,3,4)
Use (Indoor 3)	Disuse	Not set (0)	Not set (0)	1~3	Not set (0)	Slave (All)
Use (Indoor 4)	Use	Not set (0)	Not set (0)	Not set (0)	5~7	Master (Indoor 4), Slave (Indoor 1,2,3)

4-1-4 Changing the addresses and options individually

When you want to change the value of a specific option, refer to the following table and follow the steps in **Common steps for setting the addresses and options** on page <?>.

Option	SEG1		SEG2		SEG3		SEG4		SEG5		SEG6	
Function	Page		Mode		Option mode to change		Tens position of the option number		Units position of the option number		New value	
Indication and details	Indication	Details	Indication	Details	Indication	Details	Indication	Details	Indication	Details	Indication	Details
		0		D		Option type	0 to F	Tens position value	0 to 9	Units position value	0 to 9	New value

Example: Changing the Buzzer control (SEG17) option of the installation options to 1 disuse.

Option	SEG1		SEG2		SEG3		SEG4		SEG5		SEG6	
Function	Page		Mode		Option mode to change		Tens position of the option number		Units position of the option number		New value	
Indication	0		D		2		1		7		1	

Detection of errors

- ◆ If an error occurs during the operation, an LED flickers and the operation is stopped except the LED.
- ◆ If you re-operate the air conditioner, it operates normally at first, then detect an error again.
- ◆ If you turn off the air conditioner when the LED is flickering, the LED is also turned off.
- ◆ If you re-operate the air conditioner, it operates normally at first, then detect an error again.
- ◆ When E108 error occurs, change the address and reset the system.Ex.) When address of the indoor unit #1 and #2 are set as 5, address of the indoor unit #1 will become 5 and indoor unit #2 will display E108, A002.

● On ○ Flickering ✕ Off

Abnormal condition	Error code	LED Display		
Error on indoor temperature sensor (Short or Open)	E121	✕	●	✕
1. Error on Eva-in sensor (Short or Open)	E122	●	●	✕
2. Error on Eva-out sensor (Short or Open)	E123	●	●	✕
3. Discharge sensor error (Short or Open)	E126	●	●	✕
Indoor fan error	E154	✕	✕	●
1. Error on outdoor temperature sensor (Short or Open)	E221	●	✕	●
2. Error on cond sensor	E237	●	✕	●
3. Error on discharge sensor	E251	●	✕	●
Other outdoor unit sensor error that is not on the above list		●	✕	●
1. When there is no communication between the indoor•outdoor units for 2 minutes	E101	✕	●	●
2. Communication error received from the outdoor unit	E102			
3. 3 minute tracking error on outdoor unit	E202			
4. Communication error after tracking due to unmatching number of installed units	E201			
5. Error due to repeated communication address	E108			
6. Communication address not confirmed	E109			
Other outdoor unit communication error that is not on the above list		✕	●	●
Self diagnosis error display				
1. Error due to opened EEV (2nd detection)	E151	●	●	●
2. Error due to closed EEV (2nd detection)	E152			
3. Eva in sensor is detached	E128			
4. Eva out sensor is detached	E129			
5. Thermal fuse error (Open)	E198			
1. COND mid sensor is detached	E241	●	●	●
2. Refrigerant leakage (2nd detection)	E554			
3. Abnormally high temperature on Cond (2nd detection)	E450			
4. Low pressure s/w (2nd detection)	E451			
5. Abnormally high temperature on discharged air on outdoor unit (2nd detection)	E416			
6. Indoor operation stop due to unconfirmed error on outdoor unit	E559			
7. Error due to reverse phase detection	E425			
8. Comp stop due to freeze detection (6th detection)	E403			
9. High pressure sensor is detached	E301			
10. Low pressure sensor is detached	E306			
11. Outdoor unit copression ration error	E428			
12. Outdoor sump down_1 prevention control	E413			
13. Compressor down due to low pressure sensor prevention control_1	E410			
14. Simultaneous opening of cooling/heating MCU SOL valve (1st detection)	E180			
15. Simultaneous opening of cooling/heating MCU SOL valve (2nd detection)	E181			
Other outdoor unit self-diagnosis error that is not on the above list		●	●	●
EEPROM error	E162	●	●	●
EEPROM option error	E163	●	●	●

4-2 Troubleshooting for outdoor unit



The table below list the self-diagnostic routines. For some of error codes, you must contact an authorized service centre. If an error occurs during the operation, it is displayed on the outdoor unit PCB LED, both MAIN PCB and INVERTER PCB.

No.	Error Code	Meaning	Remarks
1	E108	Error due to duplicated communication address	Check on repeated indoor unit main address
2	E121	Error on room temperature sensor of indoor unit (Short or Open)	Indoor unit Room Thermistor Open/Short
3	E122	Error on EVA IN sensor of indoor unit (Short or Open)	Indoor unit EVA_IN Thermistor Open/Short
4	E123	Error on EVA OUT sensor of indoor unit (Short or Open)	Indoor unit EVA_OUT Thermistor Open/Short
5	E153	Error on float switch (2nd detection)	Indoor unit Float Switch Open/Short Drain Pump operation Check
6	E154	Indoor fan error	Check on indoor unit indoor Fan operation
7	E198	Error on thermal fuse of indoor unit (Open)	Thermal Fuse Open Check of indoor unit Terminal Block
8	E201	Communication error between the indoor unit and outdoor unit (Pre-tracking failure or when the actual number of indoor units are different from the indoor unit quantity setting on the outdoor unit) Error due to communication tracking failure after initial power is supplied (The error occurs regardless of the number of units.)	Check indoor quantity setting in outdoor
9	E202	Communication error between indoor unit and outdoor unit (When there is no response from indoor units after tracking is completed)	Check electrical connection and setting between indoor unit and outdoor unit
10	E203	Communication error between the outdoor unit and main micom (For PF #4 to #6 controllers, error will be determined from the time when the compressor is turned on.)	Check electrical connection and setting between indoor unit MAIN PBA - INVERTER PBA
11	E221	Error on outdoor temperature sensor (Short or Open)	Check Outdoor sensor Open / Short
12	E231	Error on outdoor COND OUT sensor (Short or Open)	Check Cond-Out sensor Open / Short
13	E251	Error on discharge temperature sensor of compressor 1 (Short or Open)	Check Discharge sensor Open / Short
14	E320	Error on OLP sensor (Short or Open)	Check OLP sensor Open / Short
15	E403	Compressor down due to freeze protection control	Check Outdoor Cond.
16	E404	System stop due to overload protection control	Check Comp. when it starts
17	E416	System stop due to discharge temperature	-
18	E422	Blockage detected on high pressure pipe	1. Check if the service valve is open 2. Check for refrigerant leakage (pipe connections, heat exchanger) and charge refrigerant if necessary 3. Check if there's any blockage on the refrigerant cycle (indoor unit/outdoor unit) 4. Check if additional refrigerant has been added after pipe extension
19	E425	Reverse phase or open phase	Check whether 3 phase is reversed or opened.
20	E440	Heating operation restricted at outdoor temperature over Theat_high value	HEATING
21	E441	Cooling operation restricted at outdoor temperature below Tcool_low value	COOLING
22	E458	Fan speed error	FAN1 ERROR

No.	Error Code	Meaning	Remarks
23	E461	Error due to operation failure of inverter compressor	-
24	E462	System stop due to full current control	-
25	E463	Over current trip / PFC over current error	Check OLP sensor
26	E464	IPM Over Current(O.C)	IPM
27	E465	Comp. Over load error	-
28	E466	DC-Link voltage under/over error	Check AC Power and DC Link Voltage
29	E467	Error due to abnormal rotation of the compressor or unconnected wire of compressor	Check Comp wire
30	E468	Error on current sensor (Short or Open)	Check Outdoor Inverter PBA.
31	E469	Error on DC-Link voltage sensor (Short or Open)	-
32	E470	Outdoor unit EEPROM Read/Write error (Option)	Check Outdoor EEPROM Data
33	E471	Outdoor unit EEPROM Read/Write error (H/W)	Check Outdoor EEPROM PBA
34	E472	AC Line Zero Cross Signal out	-
35	E473	Comp Lock error	-
36	E474	Error on IPM Heat Sink sensor of inverter 1 (Short or Open)	Check Outdoor Inverter PBA.
37	E475	Error on inverter fan 2	FAN2 ERROR
38	E484	PFC Overload (Over current) Error	Check Outdoor Inverter PBA.
39	E485	Error on input current sensor of inverter 1 (Short or Open)	Check Outdoor EEPROM PBA
40	E500	IPM over heat error on inverter 1	Check Outdoor Inverter PBA.
41	E508	Smart install is not installed	-
42	E554	Gas leak detected	Check the refrigerant
43	E556	Error due to mismatching capacity of indoor and outdoor unit	Check the indoor and outdoor unit capacity
45	E590	Inverter EEPROM Checksum error	-
46	E660	Inverter Boot Code error	-

4-3 Troubleshooting by symptoms

4-3-1 Indoor temperature sensor (open/short)

Indoor unit display	  
Symptom	In case of open or short circuit of indoor temperature sensor
Failure	Short or leakage of the corresponding sensor

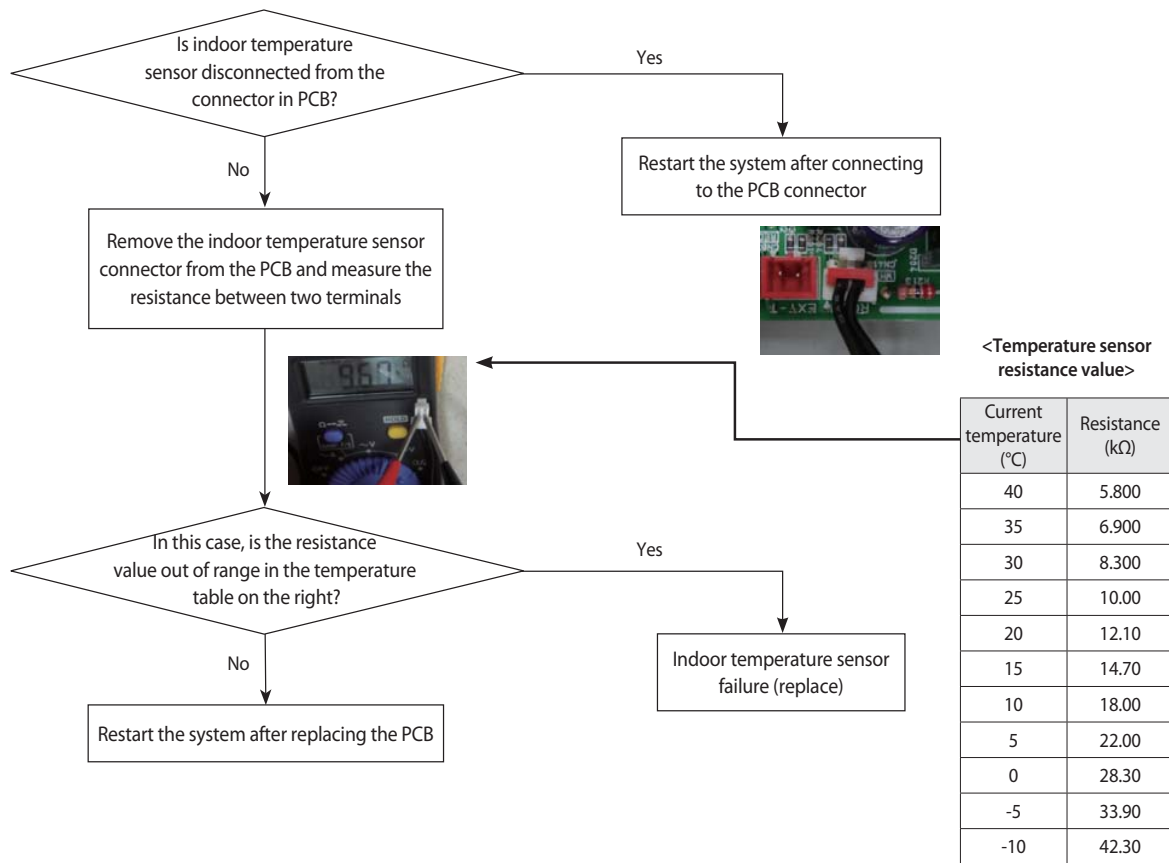

4-3-2 Indoor heat exchanger temperature sensor (open/short)

Indoor unit display	
Symptom	Short or open circuit of indoor heat exchanger temperature sensor
Failure	Short or open circuit in the corresponding sensor

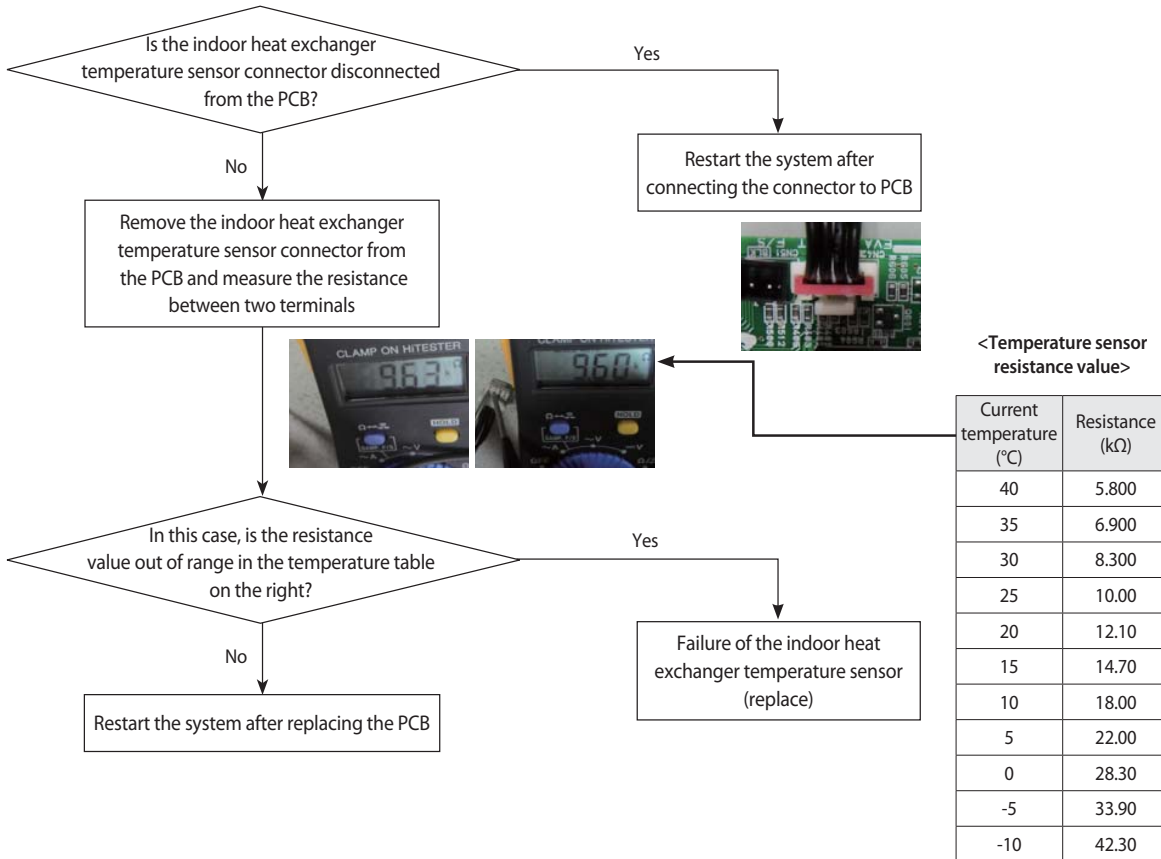

4-3-3 Indoor FAN error

Indoor unit display	
Symptom	Indoor unit fan does not run /Runs at excessive high speed and stops
Failure	Check if the motor connector is disconnected/ check the motor fan assembly status

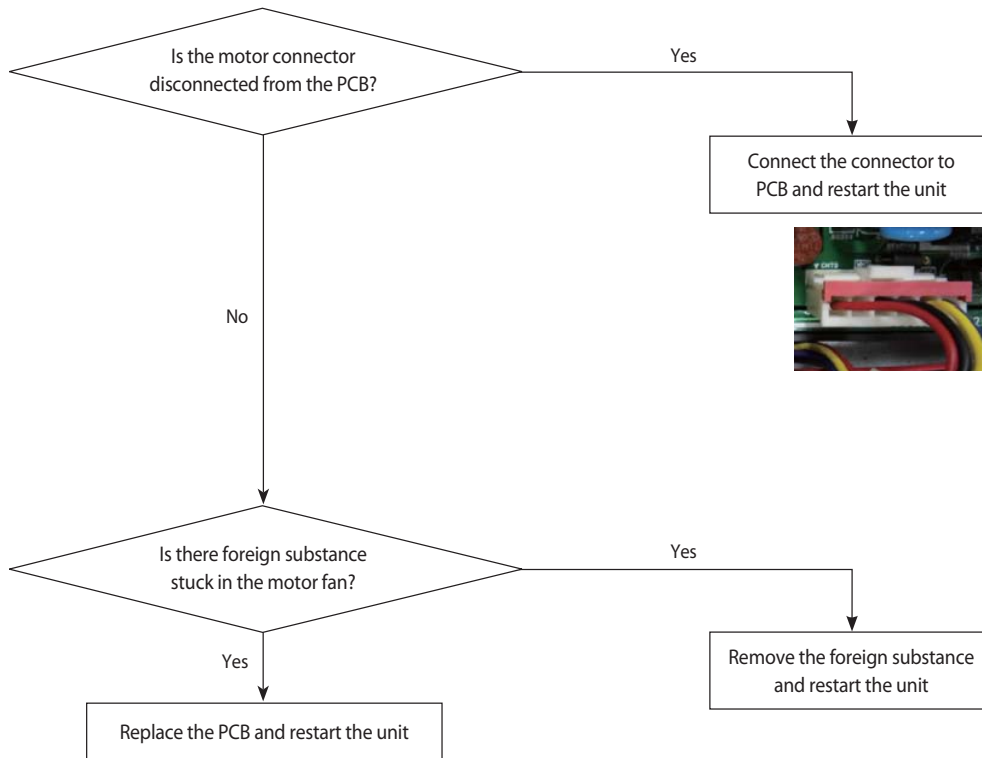

4-3-4 Communication error after finishing Tracking

Indoor unit display	
Symptom	Communication error between the indoor and outdoor unit for two minutes
Failure	Communication error between the indoor unit and outdoor unit

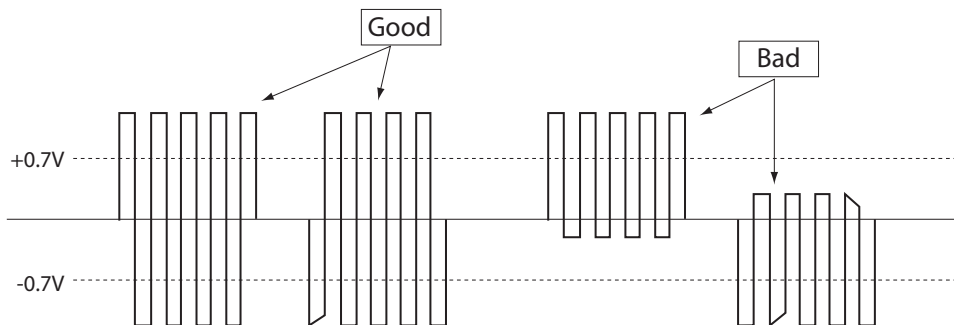
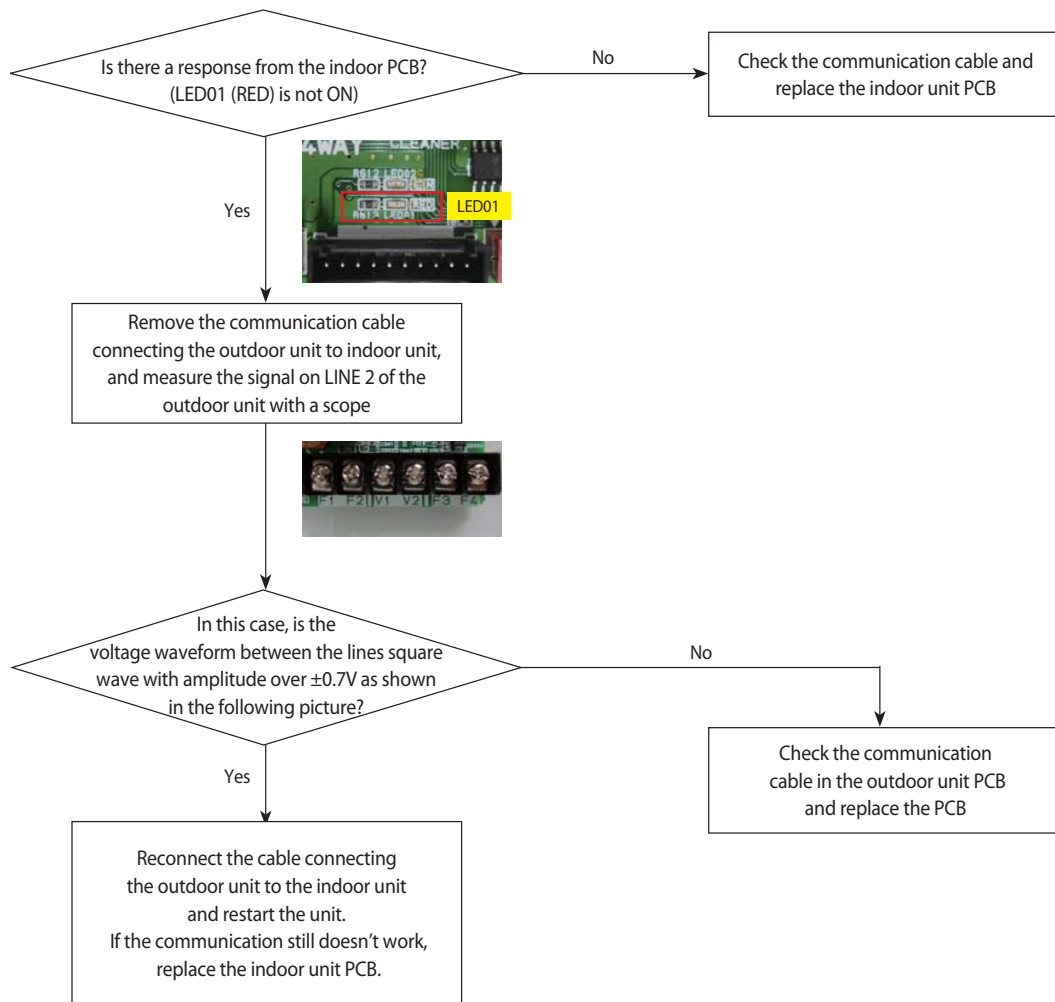

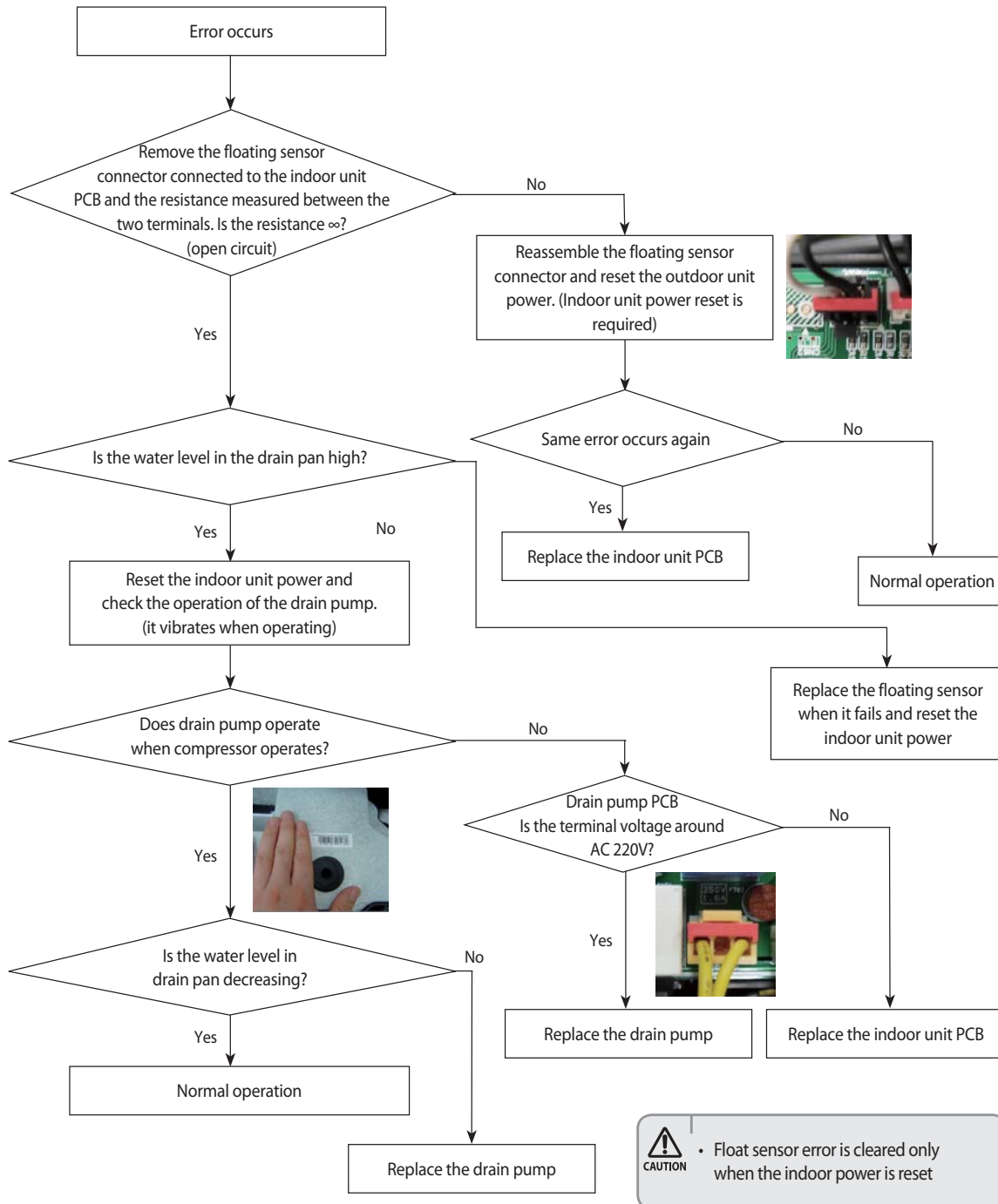

4-3-5 Indoor unit float sensor error

Indoor unit display	
Symptom	The indoor unit floating sensor is open and that state is maintained for more than one minute
Failure	Increase in the drain pan water level due to failure of the indoor unit drain pump, or float sensor failure



4-3-6 EEPROM circuit failure

Indoor unit display	  
Symptom	EEPROM circuit failure
Failure	EEPROM component failure, EEPROM circuit parts missing/damaged/soldering failure

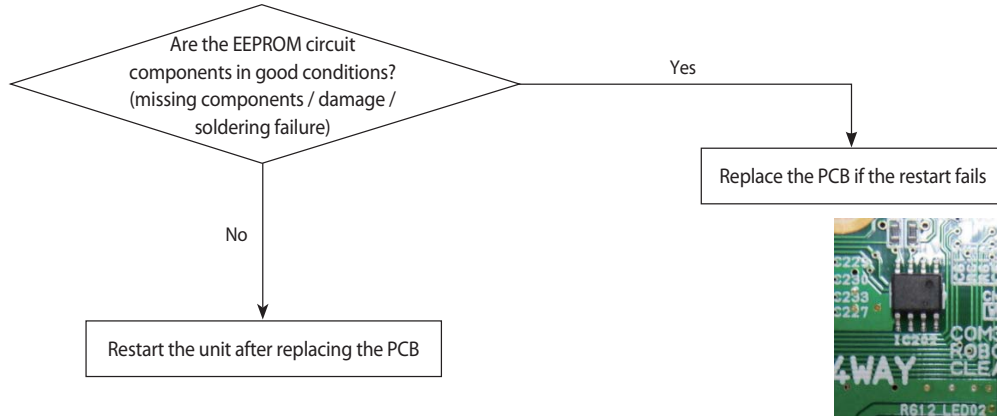

4-3-7 Outdoor unit is not powered on – Initial diagnosis

1. Check items

- 1) Is the power supply voltage 220V?
- 2) Is the AC power connected correctly?
- 3) Are the LEDs in the main PCB and inverter PCB of the outdoor unit ON?
- 4) Is the input power voltage of the indoor unit 220V?
- 5) Is the wired remote controller connected correctly?

2. Check procedure

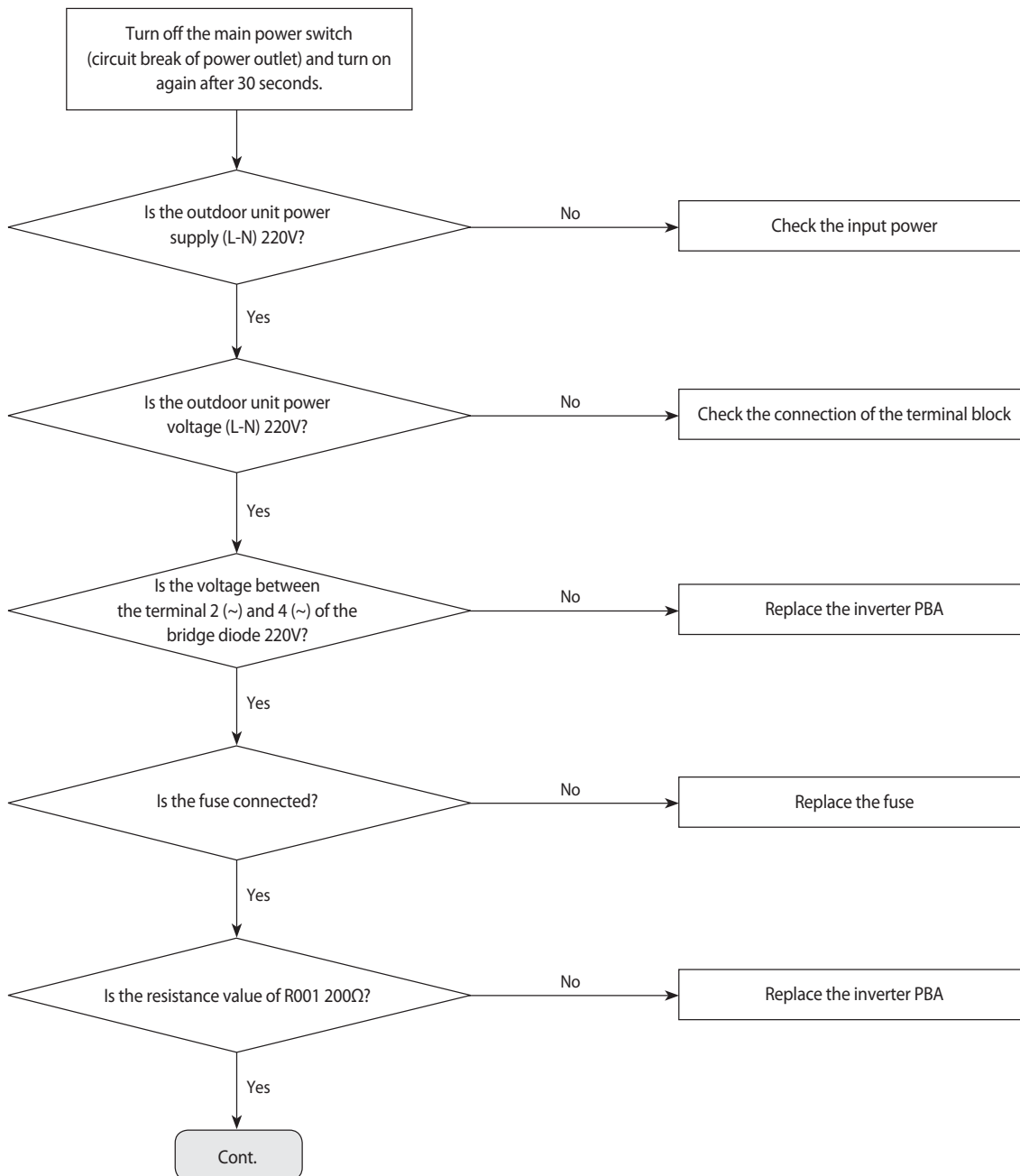

Outdoor unit is not powered on – Initial diagnosis (cont.)

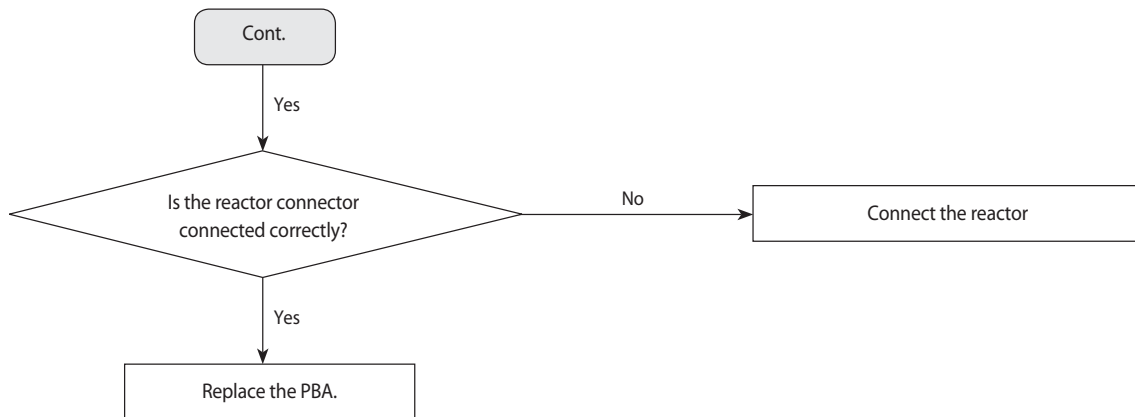

4-4-1 Communication error

1. Checklist :

- 1) Is the cable between the indoor unit and outdoor unit connected correctly?
- 2) Isn't the power cable and communication cable cross?

2. Troubleshooting procedure

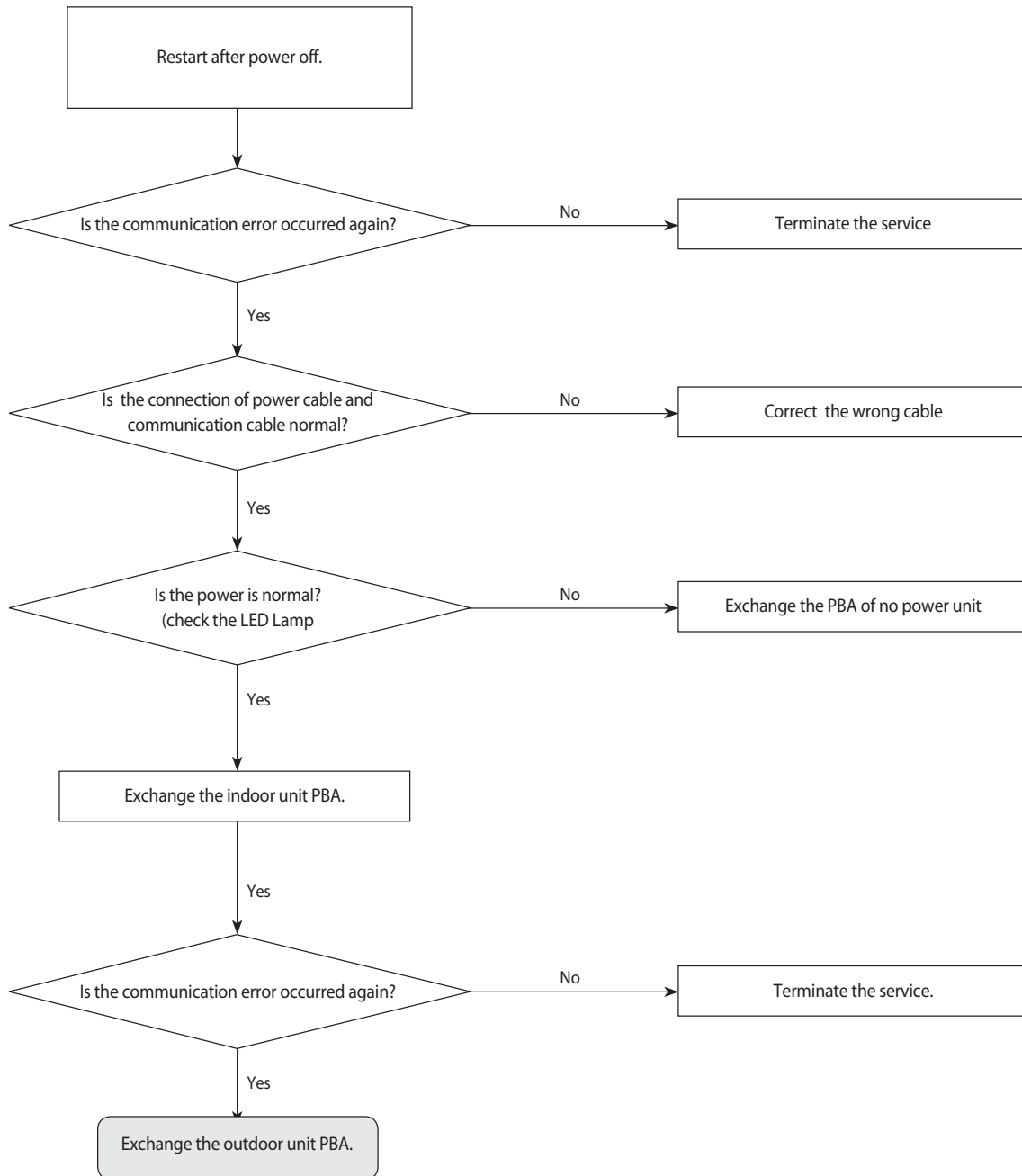

4-4-2 Outdoor temperature sensor error

1. Checklist :

- 1) Is the cable between the indoor unit and outdoor unit connected correctly?
- 2) Is the sensor placed correctly?
- 3) Does the both terminal of sensor satisfy the resistance value in accordance with temperature?
- 4) Is the resistance value of sensor connection pull-up correct?

4-4-2-1. Troubleshooting procedure (PF2)

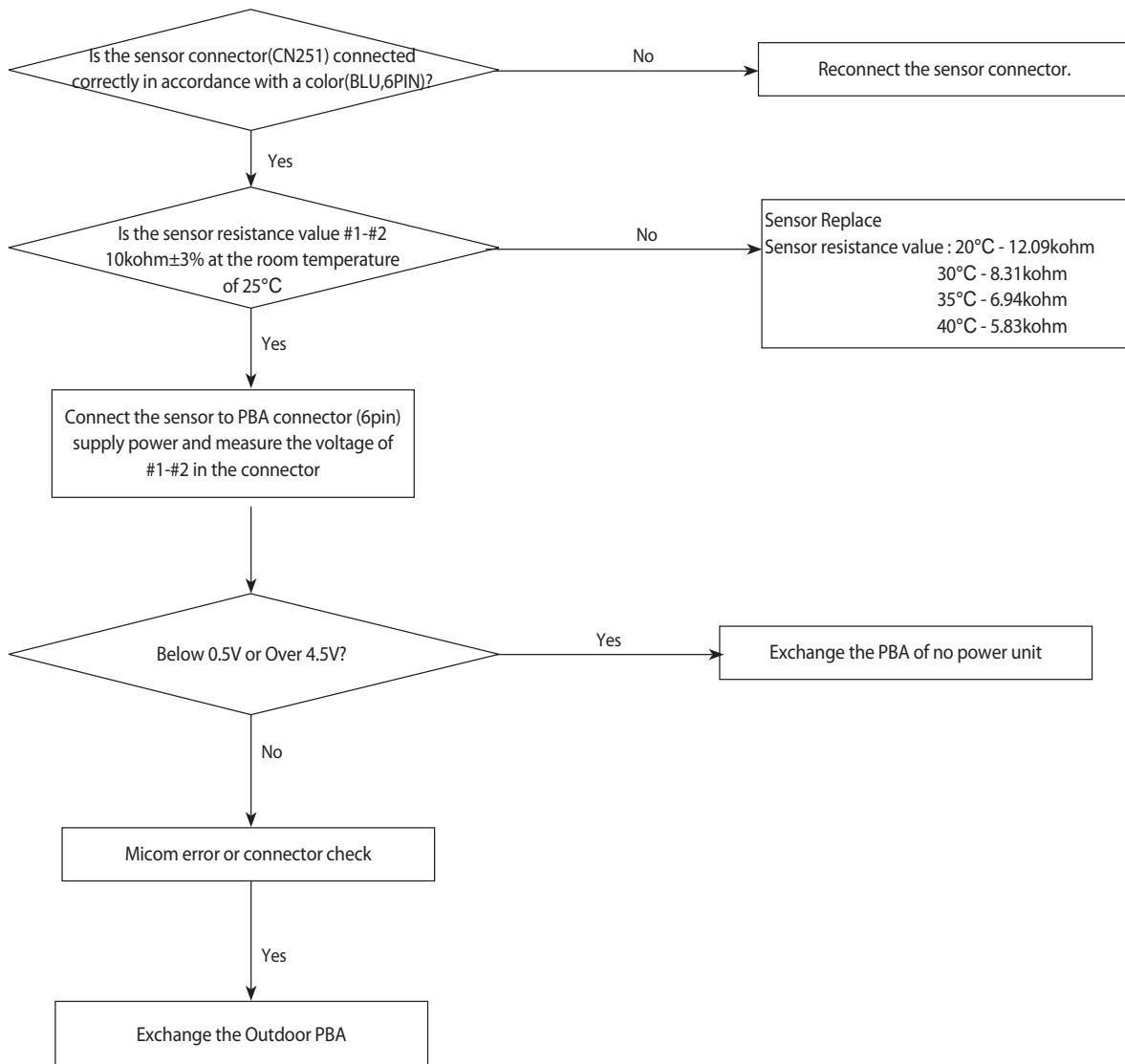

4-4-2-2. Troubleshooting procedure (PF3)

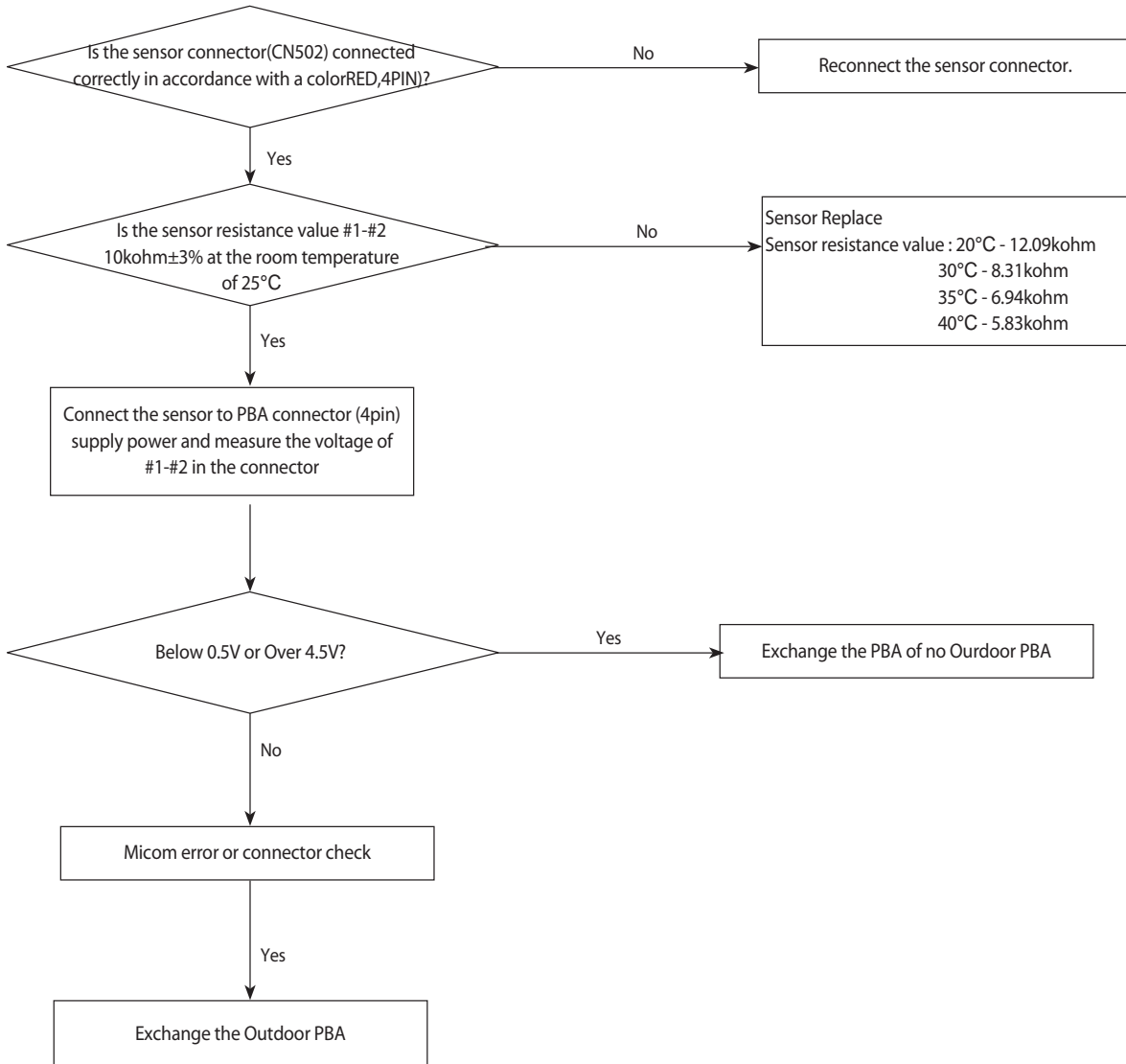

4-4-3 Outdoor Coil temperature sensor error

1. Checklist :

- 1) Is the sensor connected correctly?
- 2) Is the sensor placed correctly?
- 3) Does the both terminal of sensor satisfy the resistance value in accordance with temperature?
- 4) Is the resistance value of sensor connection pull-up correct?

4-4-3-1. Troubleshooting procedure (PF2)

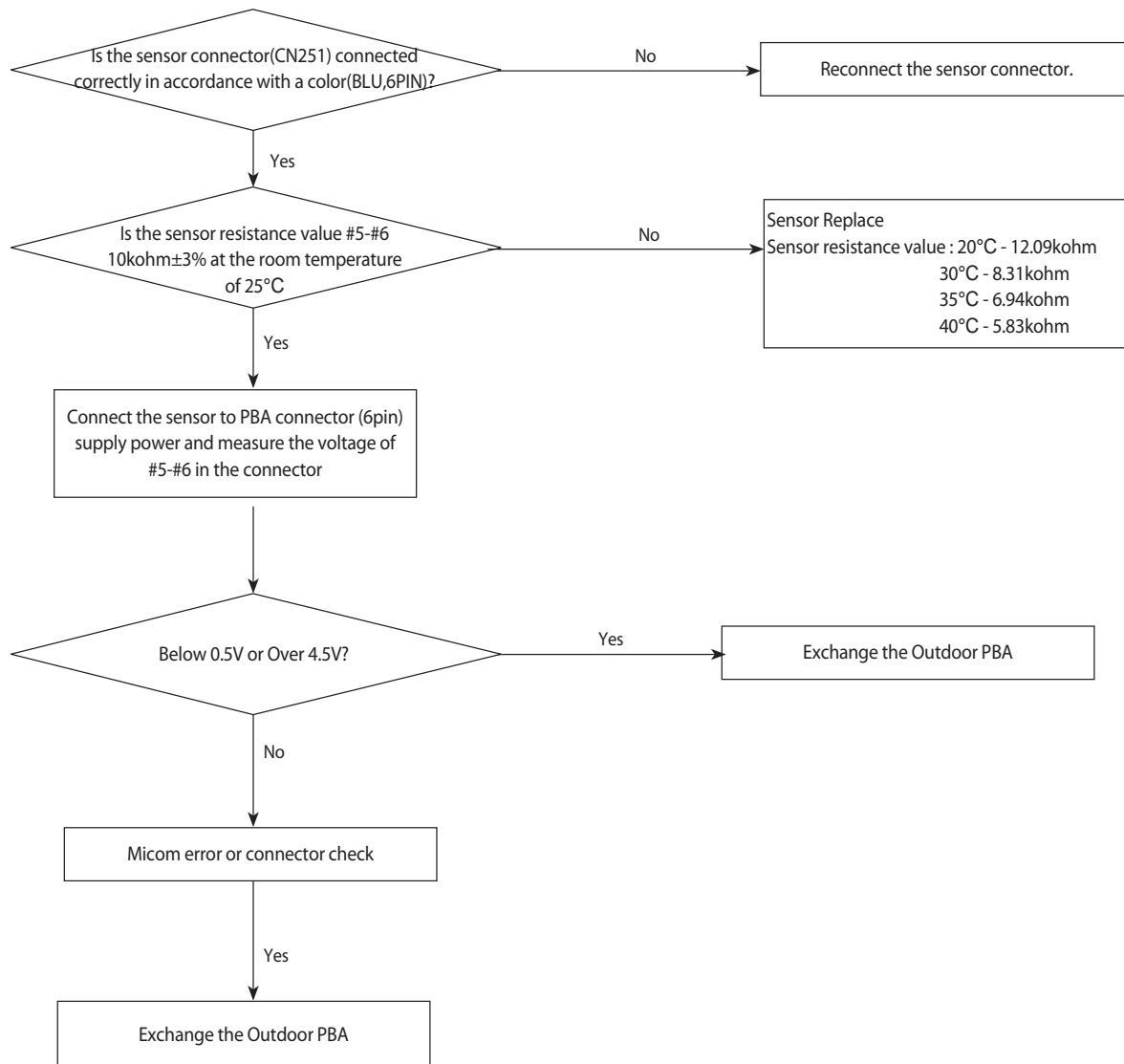

4-4-3-2. Troubleshooting procedure (PF3)

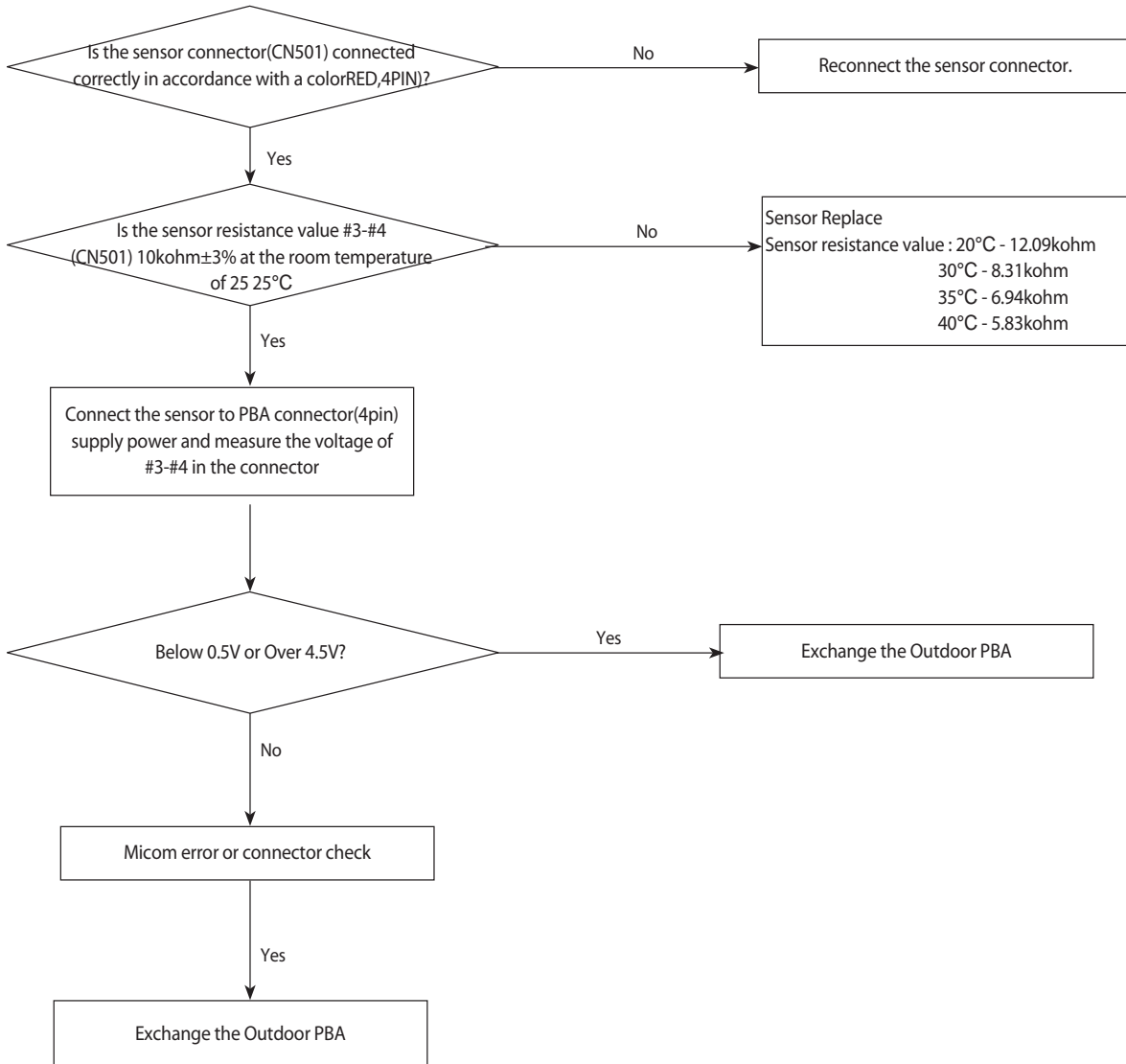

4-4-4 Outdoor Discharge temperature sensor error

1. Checklist :

- 1) Is the sensor connected correctly?
- 2) Is the sensor placed correctly?
- 3) Does the both terminal of sensor satisfy the resistance value in accordance with temperature?
- 4) Is the resistance value of sensor connection pull-up correct?

4-4-4-1. Troubleshooting procedure (PF2)

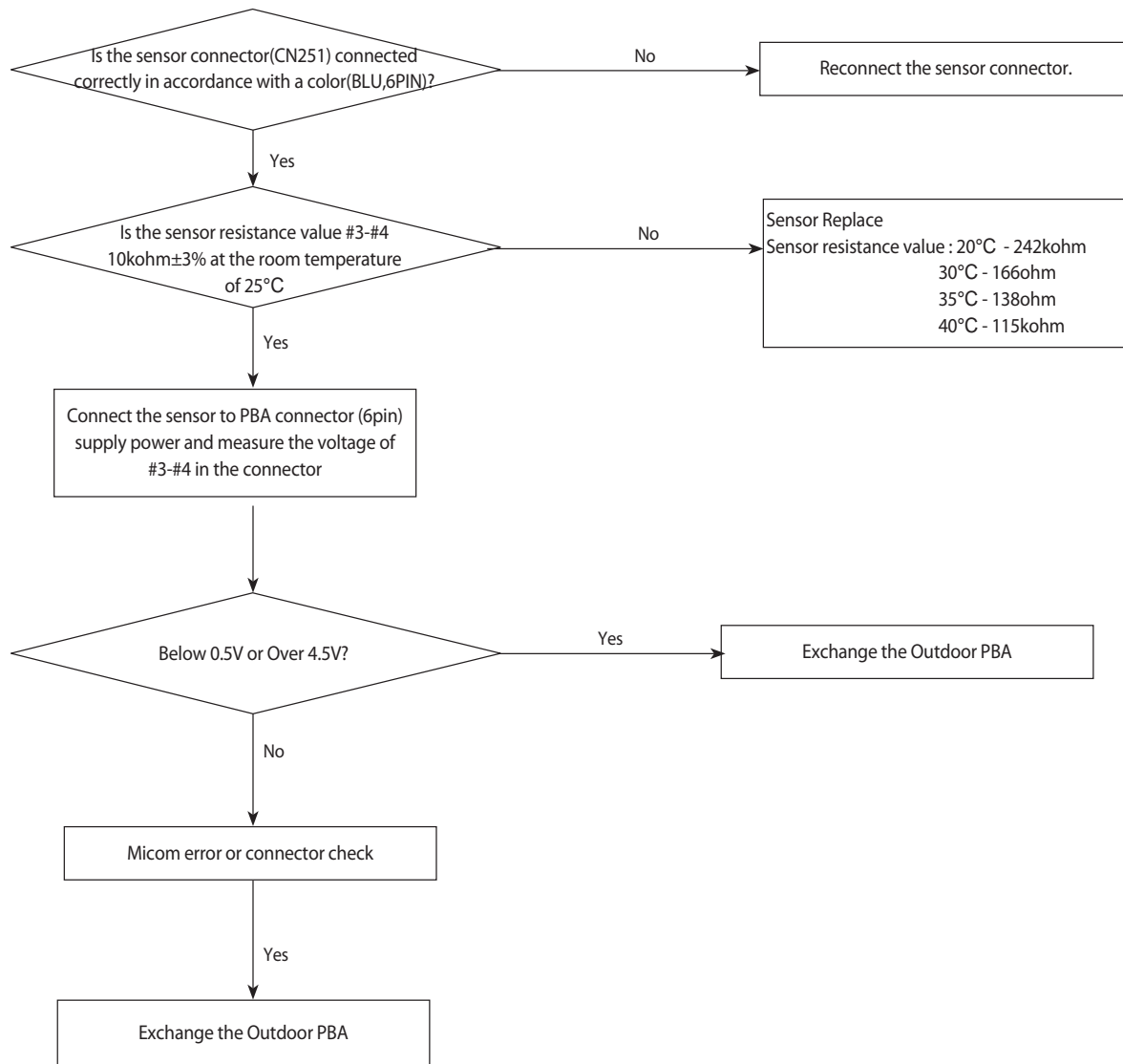

4-4-4-2. Troubleshooting procedure (PF3)

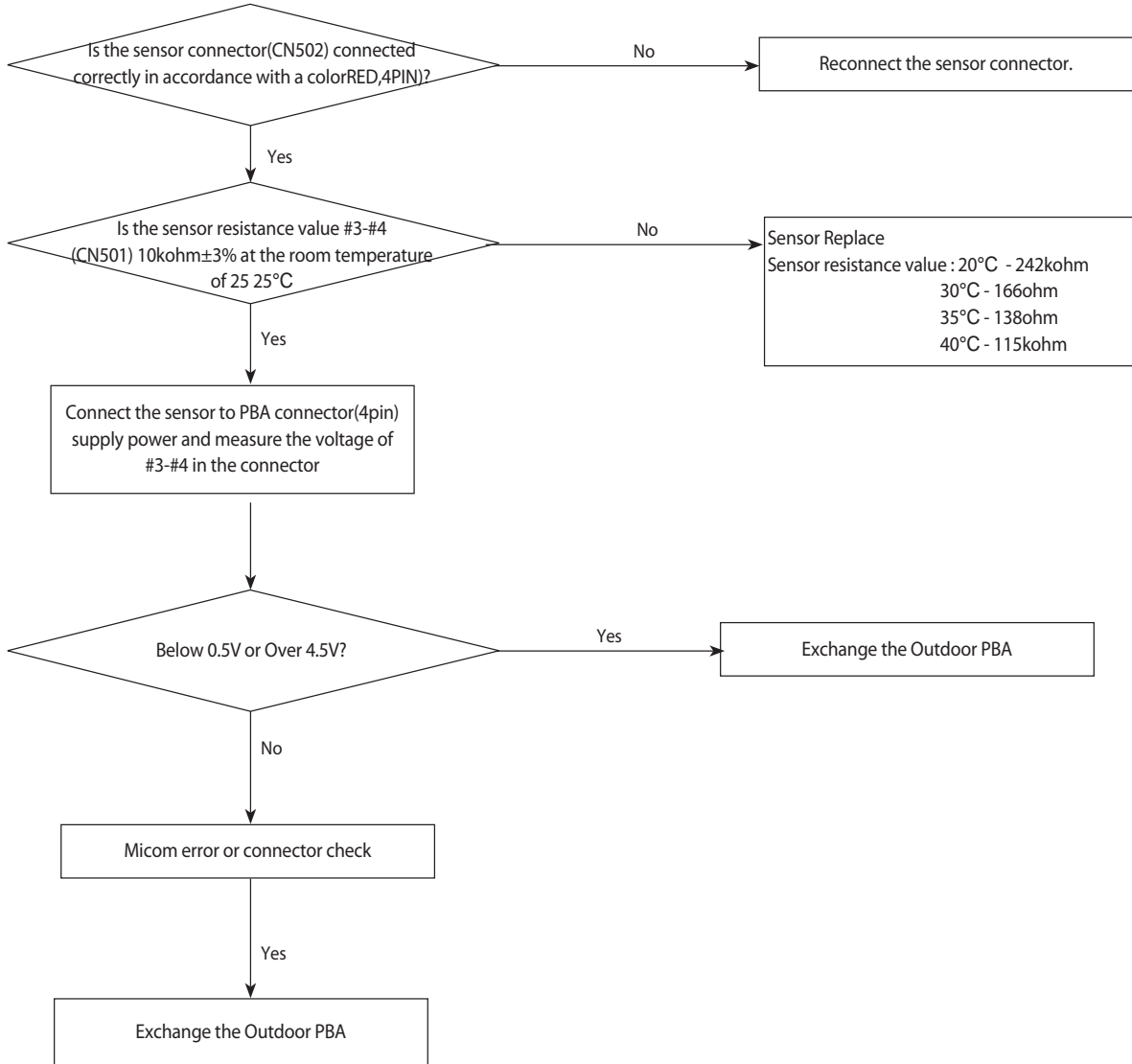

4-4-5 Outdoor Discharge over temperature error

1. Checklist :

- 1) Check the discharge temperature in the outdoor unit
- 2) Check the compressor locking or gas leak
- 3) Download the EEPROM data

2. Troubleshooting procedure

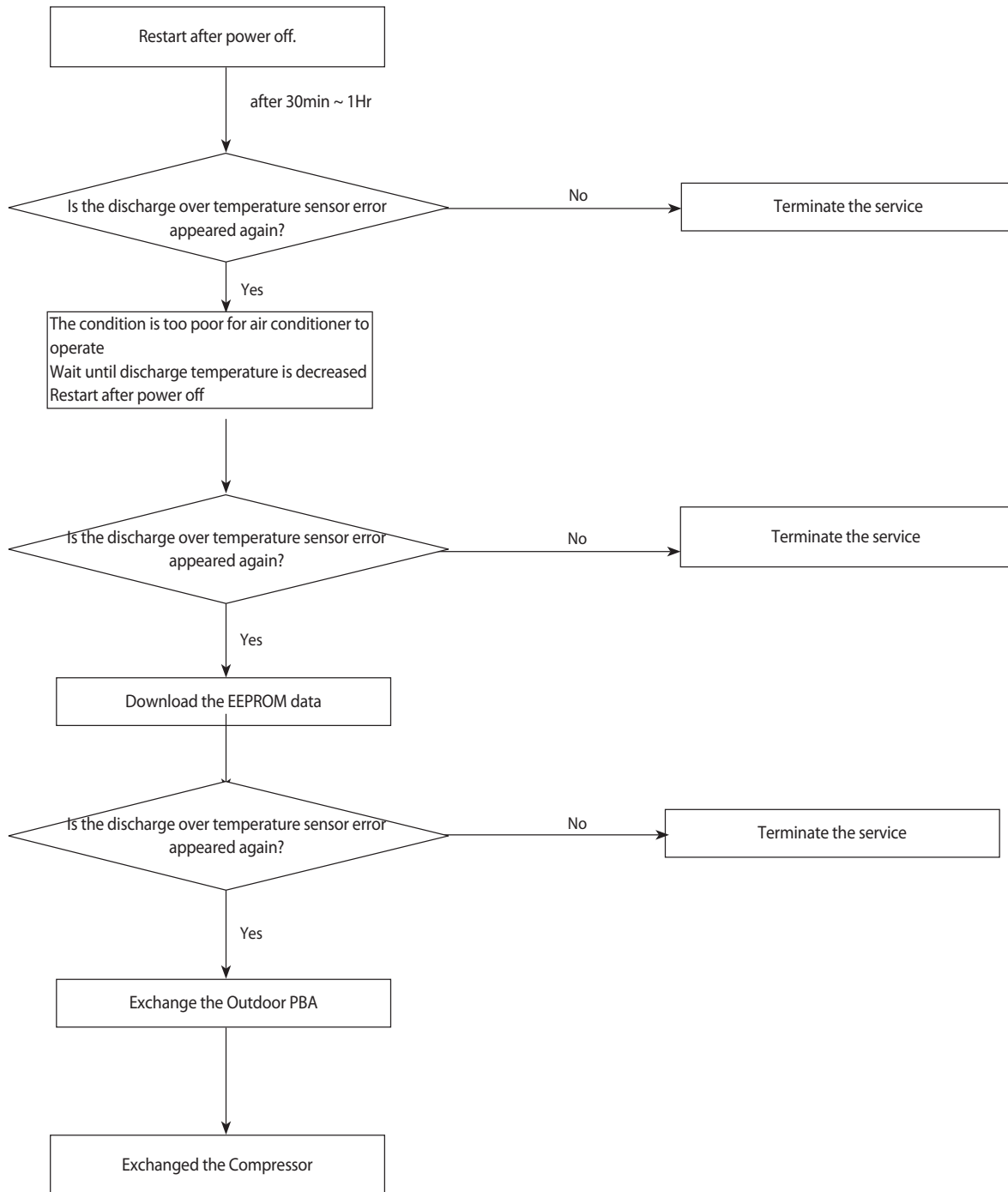

4-4-6 Outdoor Fan motor error

1. Checklist :

- 1) Are the input power voltage and the power connection correct?
- 2) Is the motor wire connected to the outdoor PBA correctly?
- 3) Is there no assembly error or none-assembly in the terminal of motor wire connector?
- 4) Is there no obstacle at the surrounding of motor and propeller?

2. Troubleshooting procedure

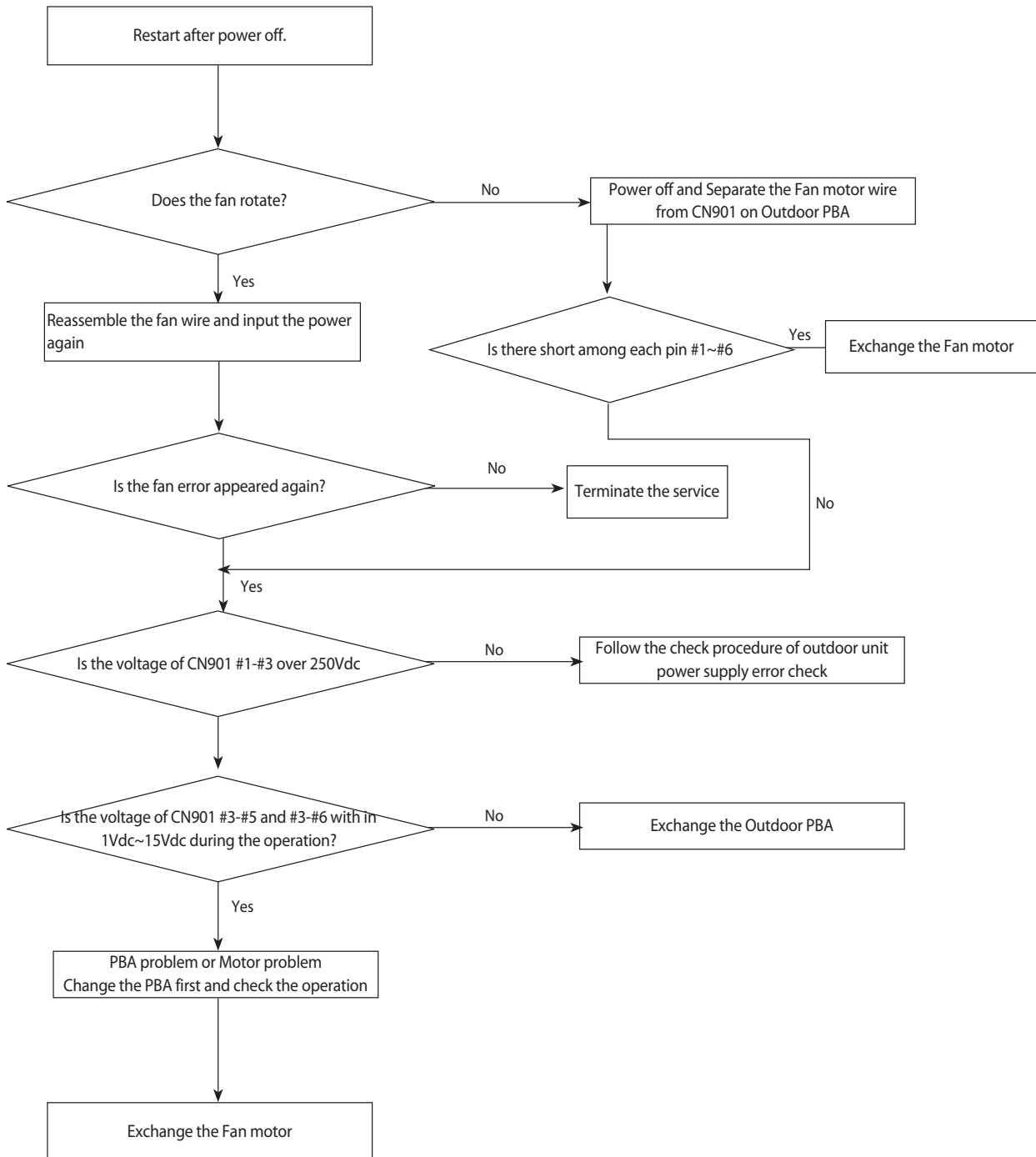

4-4-7 Compressor starting error

1. Checklist :

- 1) Is the connection of cable for the compressor?
- 2) Is the compressor wire is connected clockwise? U(RED)-V(BLU)-W(YEL)
- 3) Is the interphase resistance of compressor normal?

2. Troubleshooting procedure

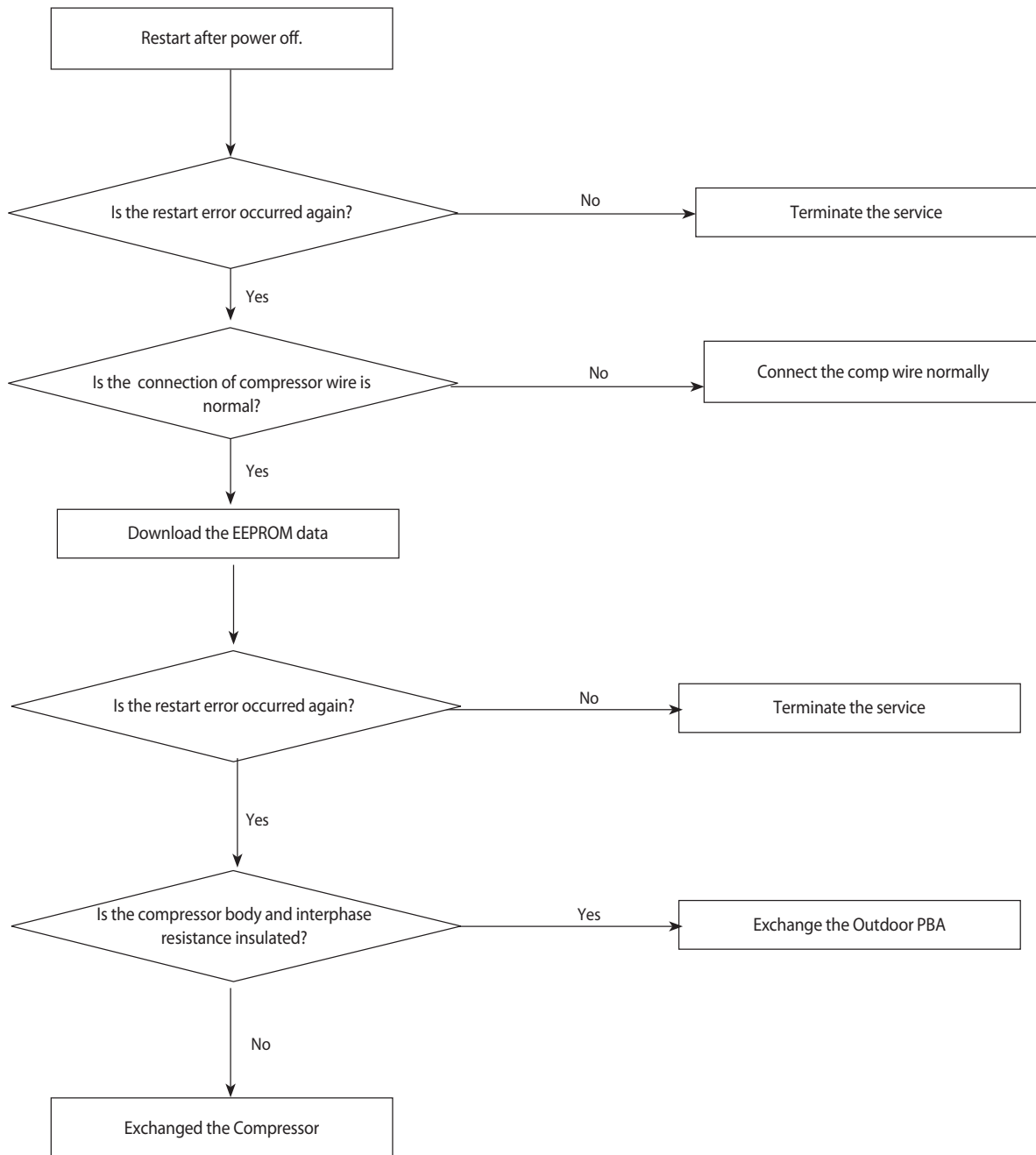

4-4-8 Compressor wire missing error/rotation error

1. Checklist :

- 1) Is the connection of cable for the compressor?
- 2) Is the compressor wire is connected clockwise? U(RED)-V(BLU)-W(YEL)
- 3) Is the interphase resistance of compressor normal?

2. Troubleshooting procedure

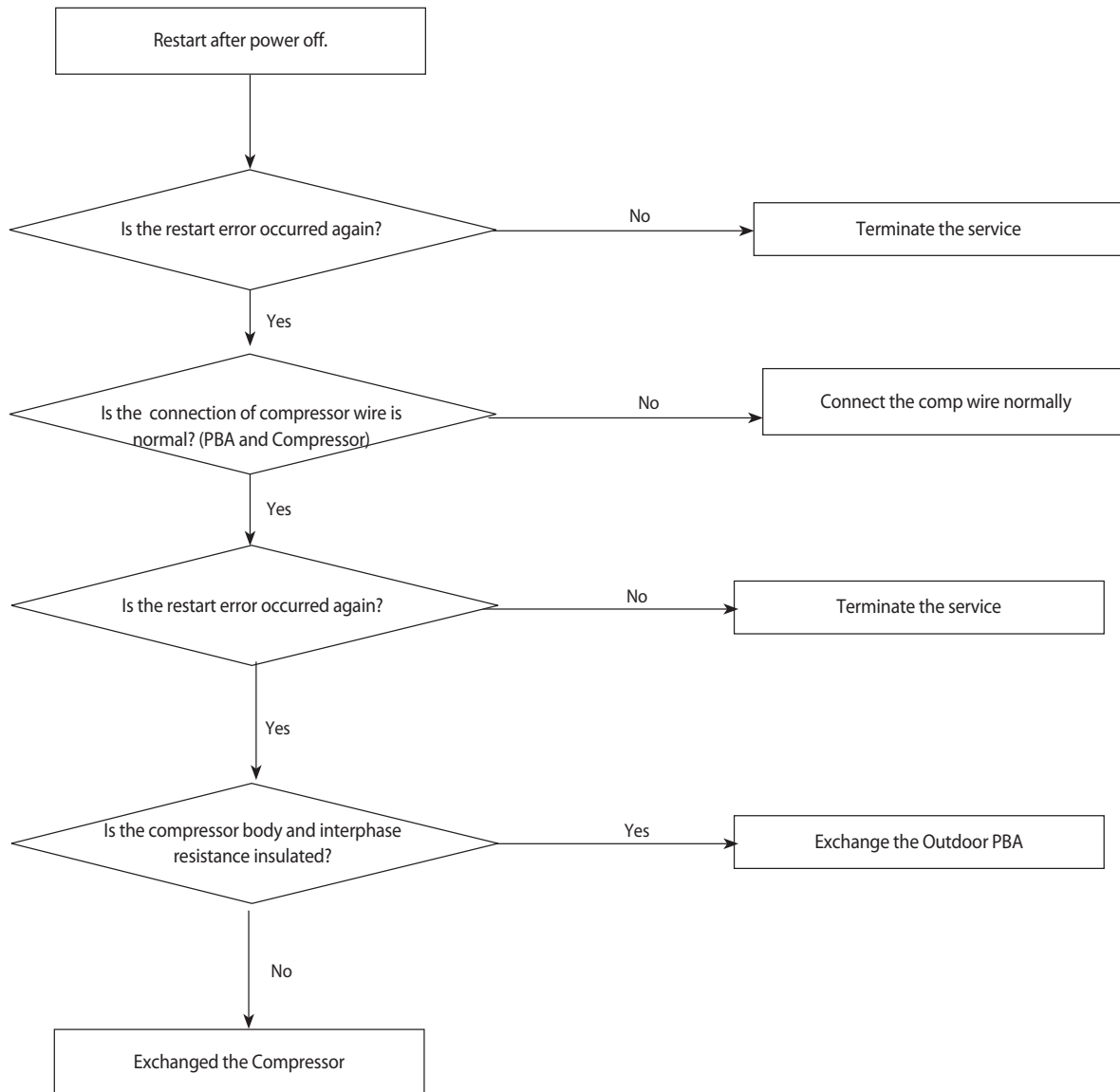

4-4-9 O.C(Over Current) error

1. Checklist :

- 1) Is the IPM Shunt(PF2:R451,R452,R453,PF3:R413,R414,R415) resistance value correct? Check the resistor is opened
- 2) Is the condition of surrounding temperature abnormal overload?
- 3) Is there any problem as like the temperature sensor separation or measurement value error?
- 4) Is the interphase resistance of compressor normal?

2. Troubleshooting procedure

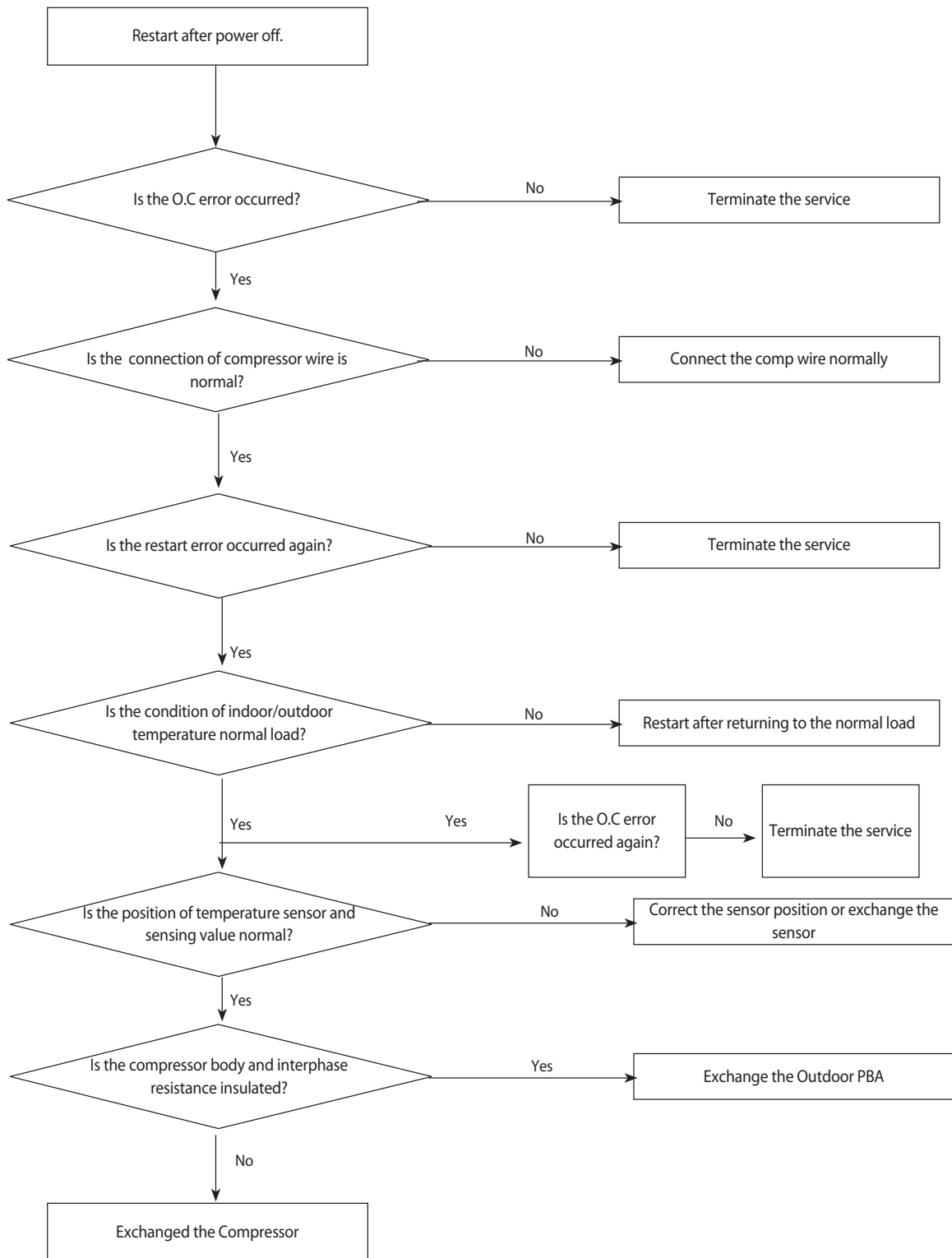

4-4-10 DC_link voltage sensor error

1. Checklist :

- 1) Is the input voltage of outdoor terminal block is normal?
- 2) Is the reactor wire connected?
- 3) Is the DC_link capacitor(PF2:CE101,CE102,CE103,PF3:CE001,CE002,CE003,CE004) assembled in accordance the specification?

(Outdoor PBA)

- 4) Is the DC_link resistor(PF2:R104,R106,R107,R108,PF3:R004,R005,R006,R007) value is normal? (Outdoor PBA)

2. Troubleshooting procedure

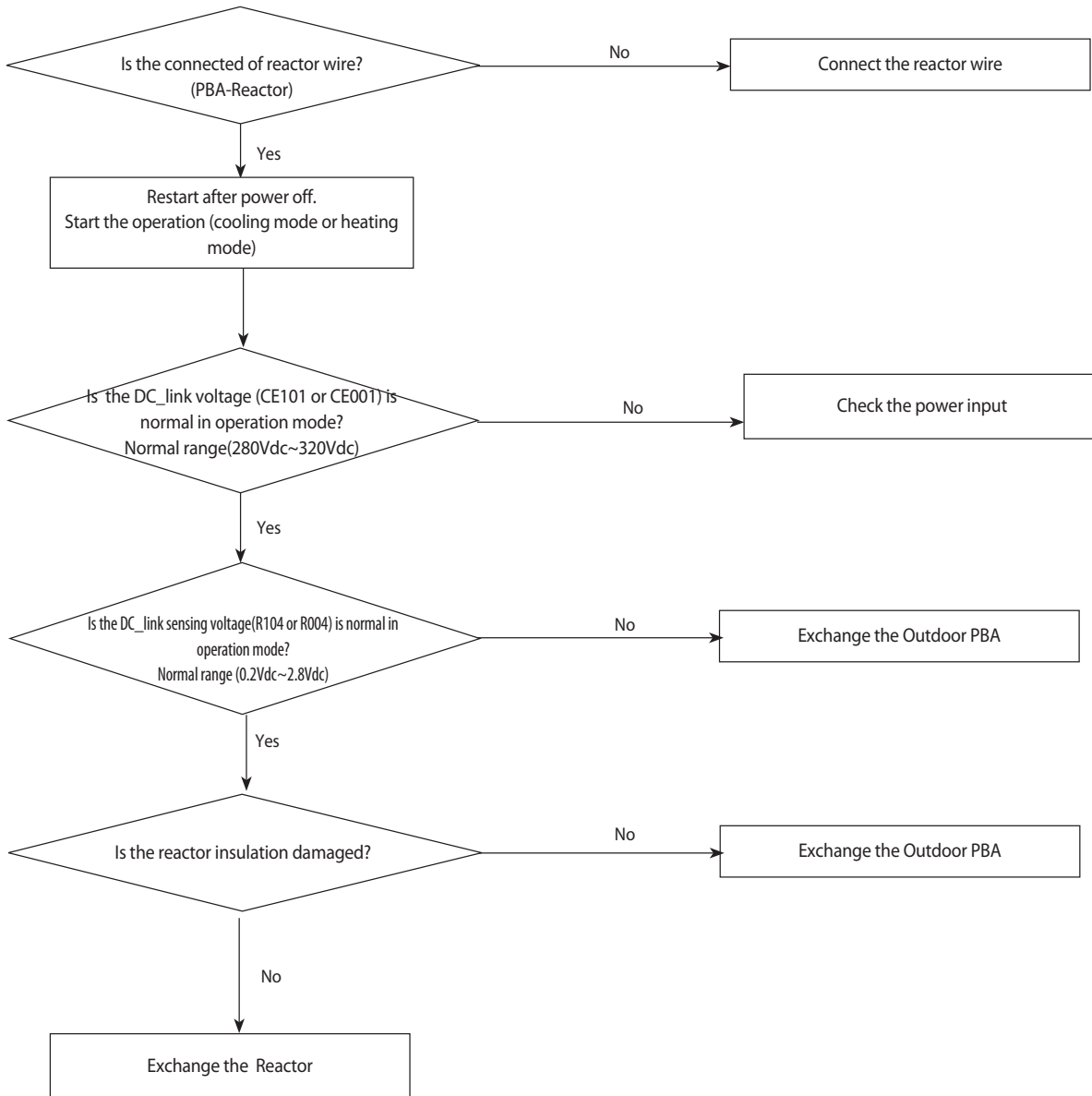

4-4-11 DC_link voltage under/over error, Over voltage protection error/PFC over load

1. Checklist :

- 1) Is the input voltage of outdoor terminal block is normal?
- 2) Is the reactor wire connected?
- 3) Is the reactor wire connected?
- 4) **Is the DC_link capacitor(PF2:CE101,CE102,CE103,PF3:CE001,CE002,CE003,CE004) assembled in accordance the specification? (Outdoor PBA)**
- 5) Is the DC_link resistor(PF2:R104,R106,R107,R108,PF3:R004,R005,R006,R007) value is normal? (Outdoor PBA)

2. Troubleshooting procedure

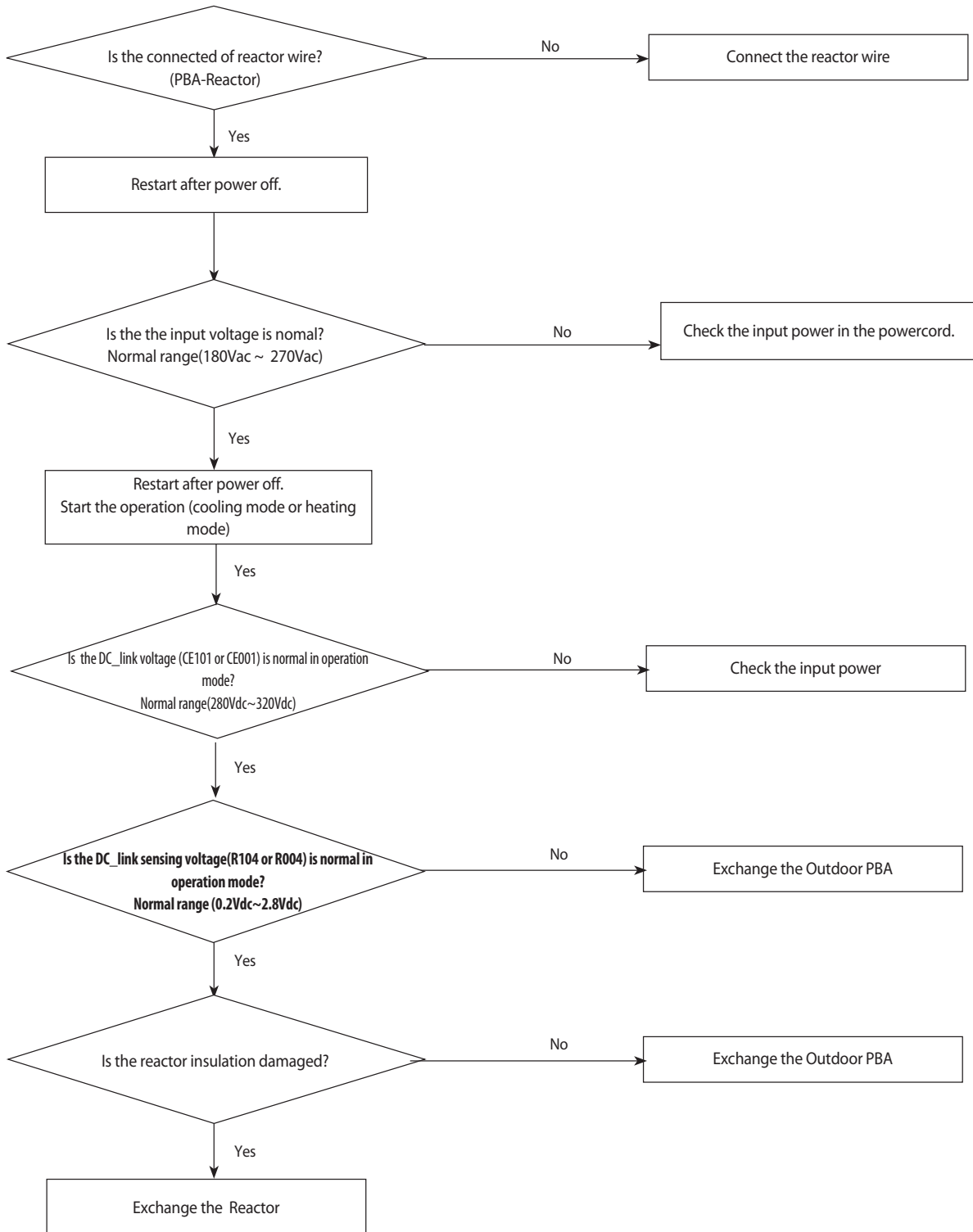

4-4-12 DC_link voltage sensor error

1. Checklist :

- 1) Is the PFC Shunt(PF2:R062,R063,PF3:R807,R808,R809) resistance value correct? Check the resistor is opened
- 2) Is the condition of surrounding temperature abnormal overload?
- 3) Is there any problem as like the temperature sensor separation or measurement value error?
- 4) Is the interphase resistance of compressor normal?

2. Troubleshooting procedure

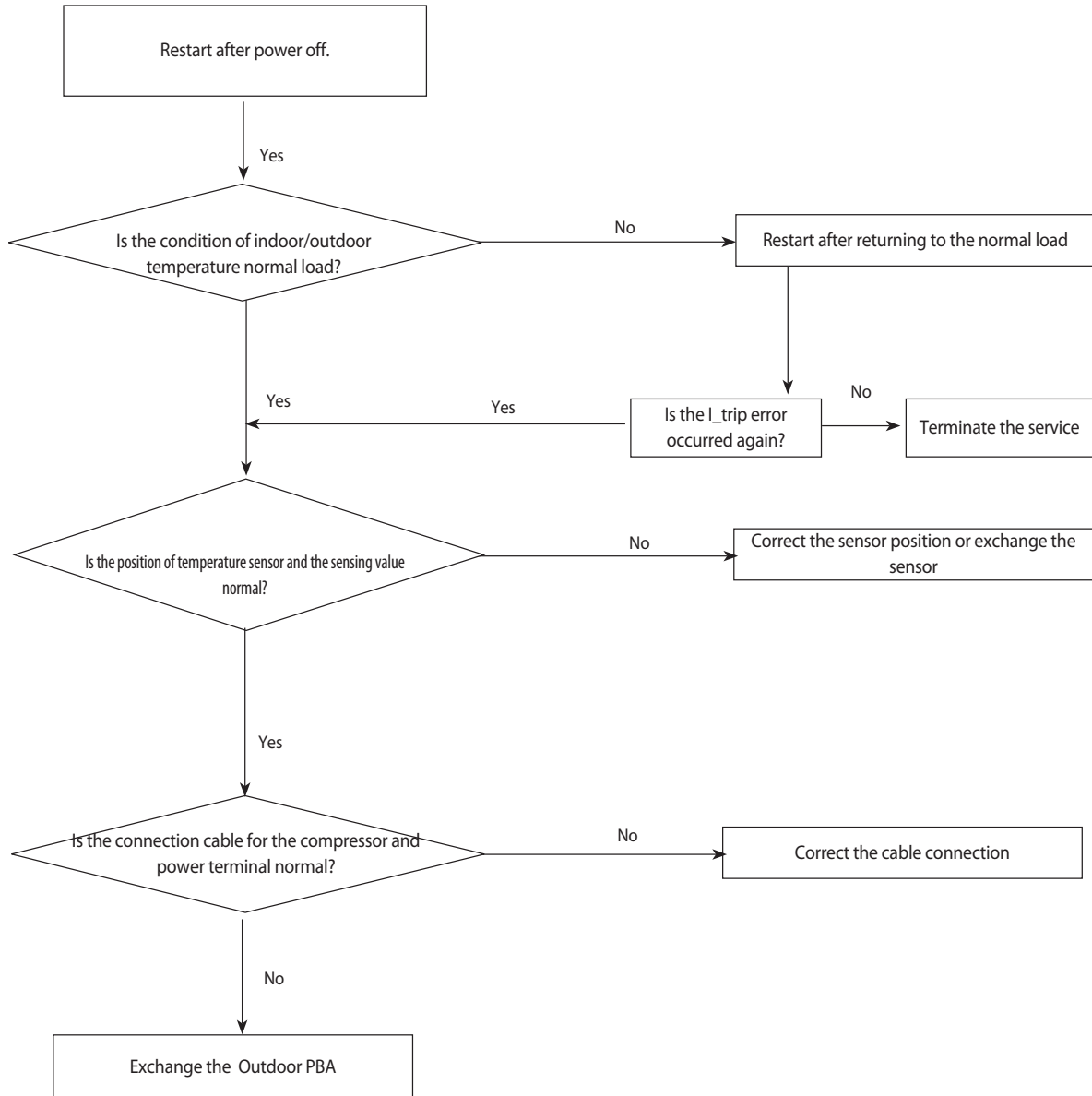

4-4-13 Current sensor error/Input current sensor error

1. Checklist :

- 1) Is the PFC Shunt(PF2:R062,R063,PF3:R807,R808,R809) resistance value correct? Check the resistor is opened
- 2) Is the IPM Shunt(PF2:R451,R452,R453,PF23:R413,R414,R415) resistance value correct? Check the resistor is opened
- 3) Is there no short or open around IC451(PF2) or IC451,IC452(PF3)?

2. Troubleshooting procedure

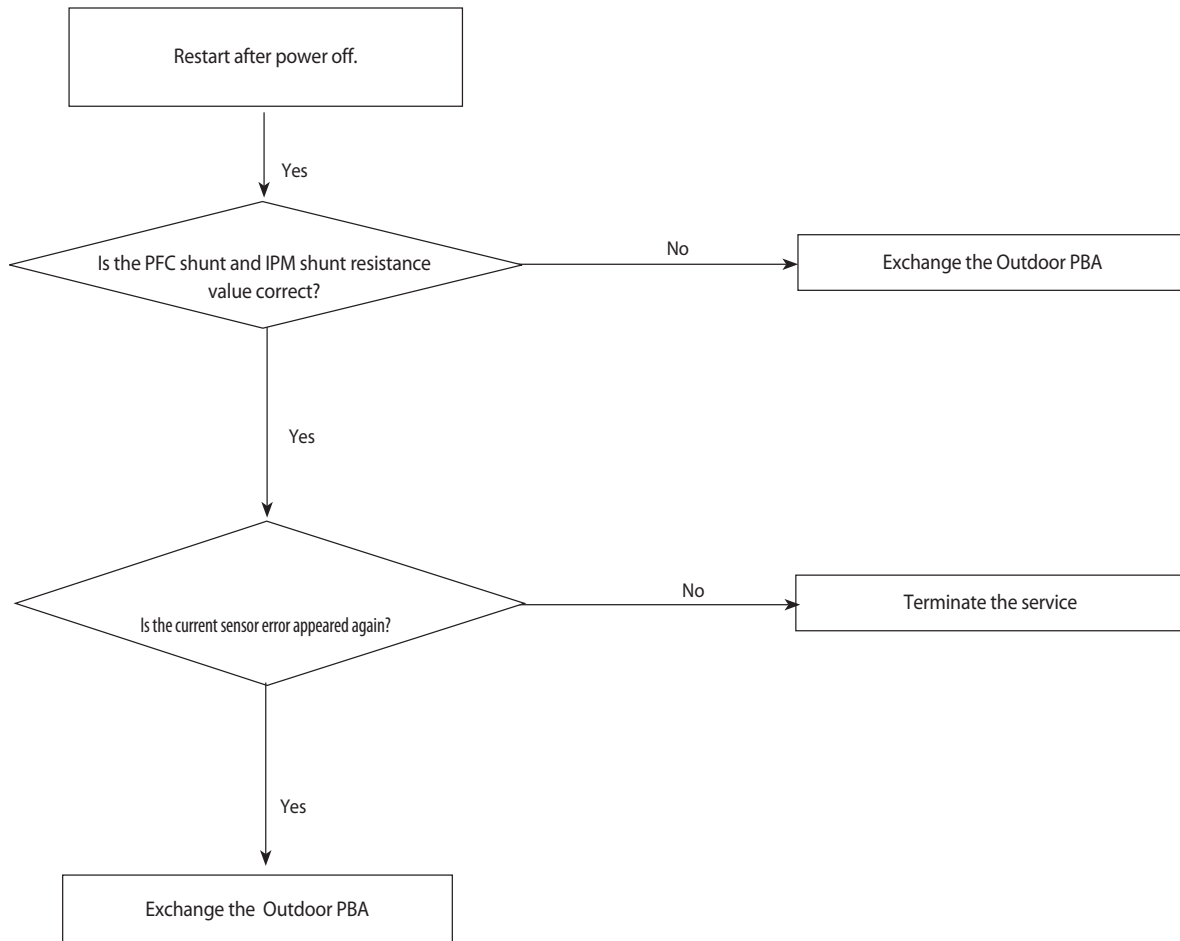

4-4-14 Heatsink sensor error/Heatsink over heat

1. Checklist :

- 1) Are there screws assembly in PBA-heatsink?
- 2) Is the gap PBA-heatsink
- 3) Is the fan operation normal?
- 4) Is the cover assembly in control-box normal?

2. Troubleshooting procedure

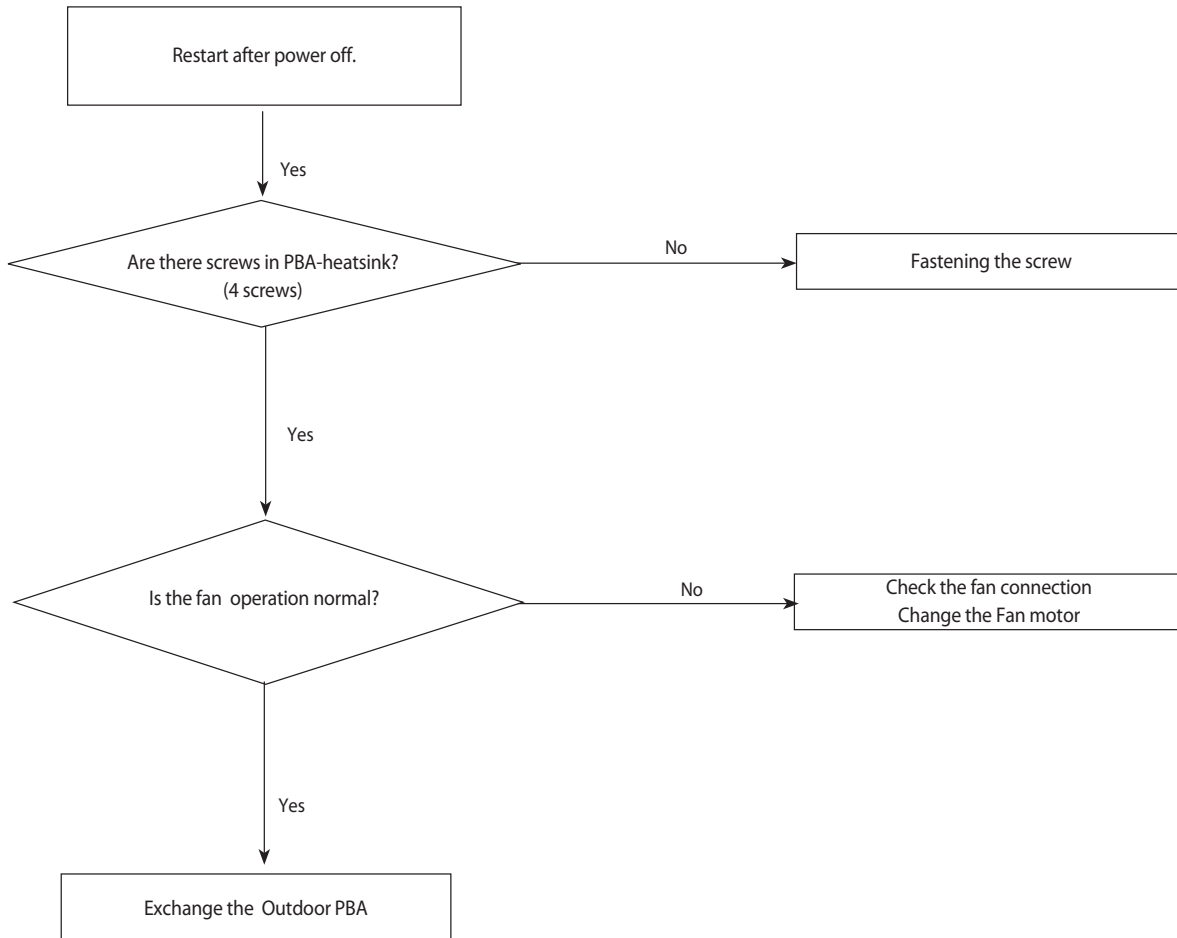

4-4-15 Comp Vlimit error/Comp current limit error

1. Checklist :

- 1) Is the PFC Shunt(PF2:R062,R063,PF3:R807,R808,R809) resistance value correct? Check the resistor is opened
- 2) Is the condition of surrounding temperature abnormal overload?
- 3) Is there any problem as like the temperature sensor separation or measurement value error?
- 4) Is the interphase resistance of compressor normal?

2. Troubleshooting procedure

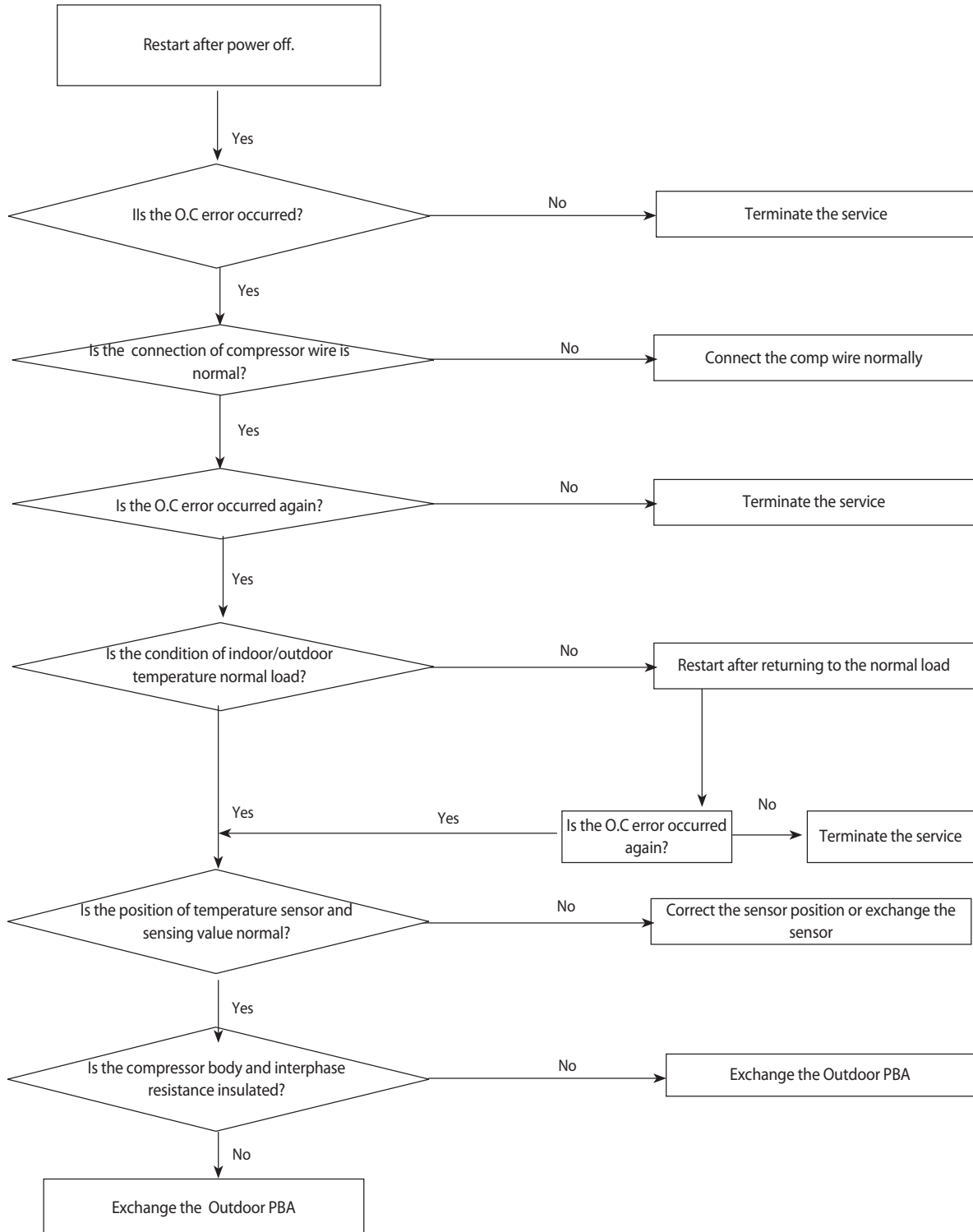

4-4-16 EEPROM error/OTP error

1. Checklist :

- 1) Is there a short around micom?
- 2) Is there a short around IC202(PF2) or IC701(PF3)?
- 3) Did you download or insert EEPROM IC, after changing outdoor PBA?

2. Troubleshooting procedure

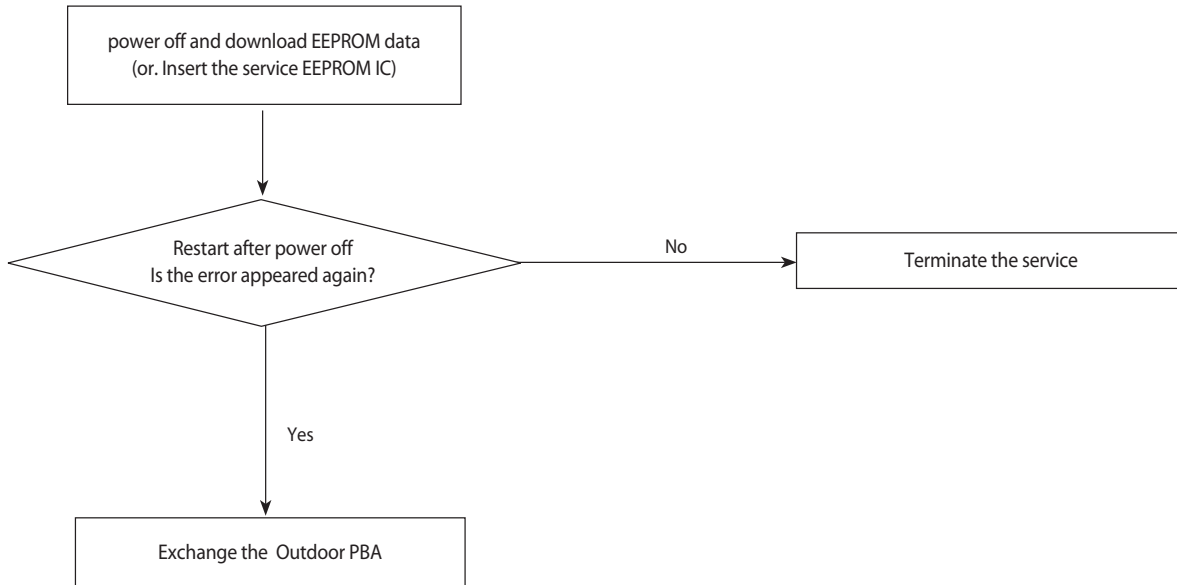

4-4-17 AC zero cross signal error

1. Checklist :

- 1) Check the power condition at customer's house (Is there any power noise?)
- 2) Have been there power failure?

2. Troubleshooting procedure

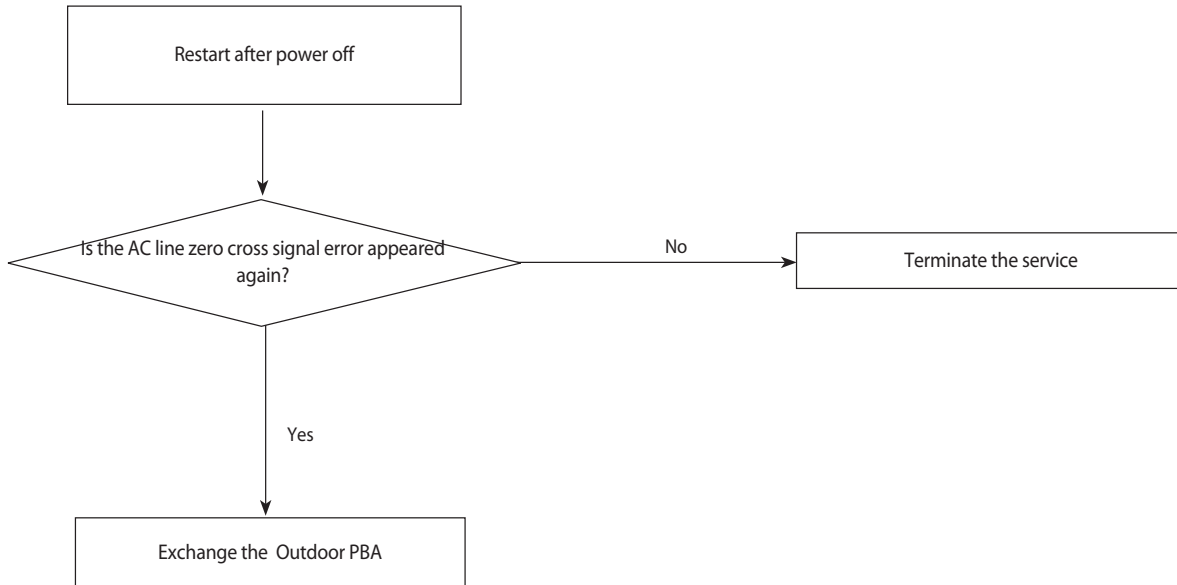

4-4-18 Operation condition secession error

1. Checklist :

- 1) Check the temperature around the outdoor unit.

2. Troubleshooting procedure

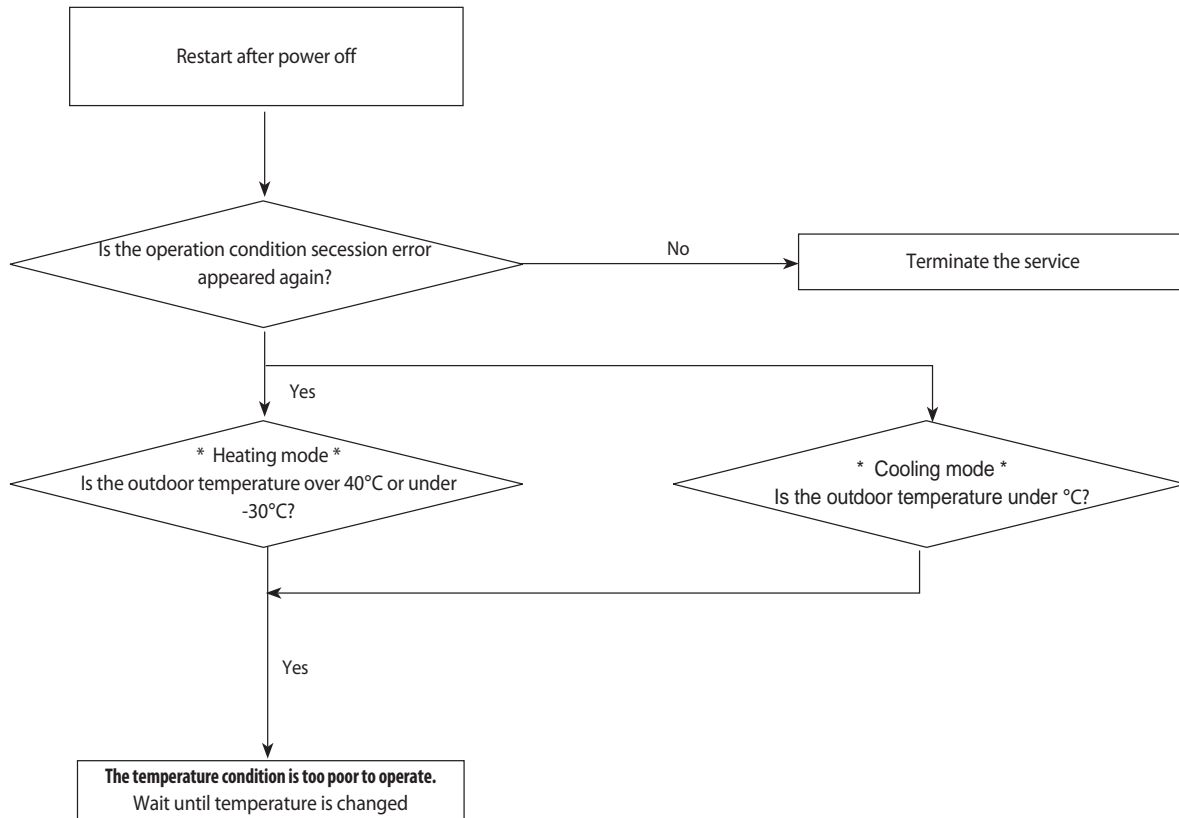

4-4-19 Capacity miss match error

1. Checklist :

- 1) Check the Btu between indoor and outdoor unit
- 2) Check the indoor unit option and outdoor unit EEPROM data

2. Troubleshooting procedure

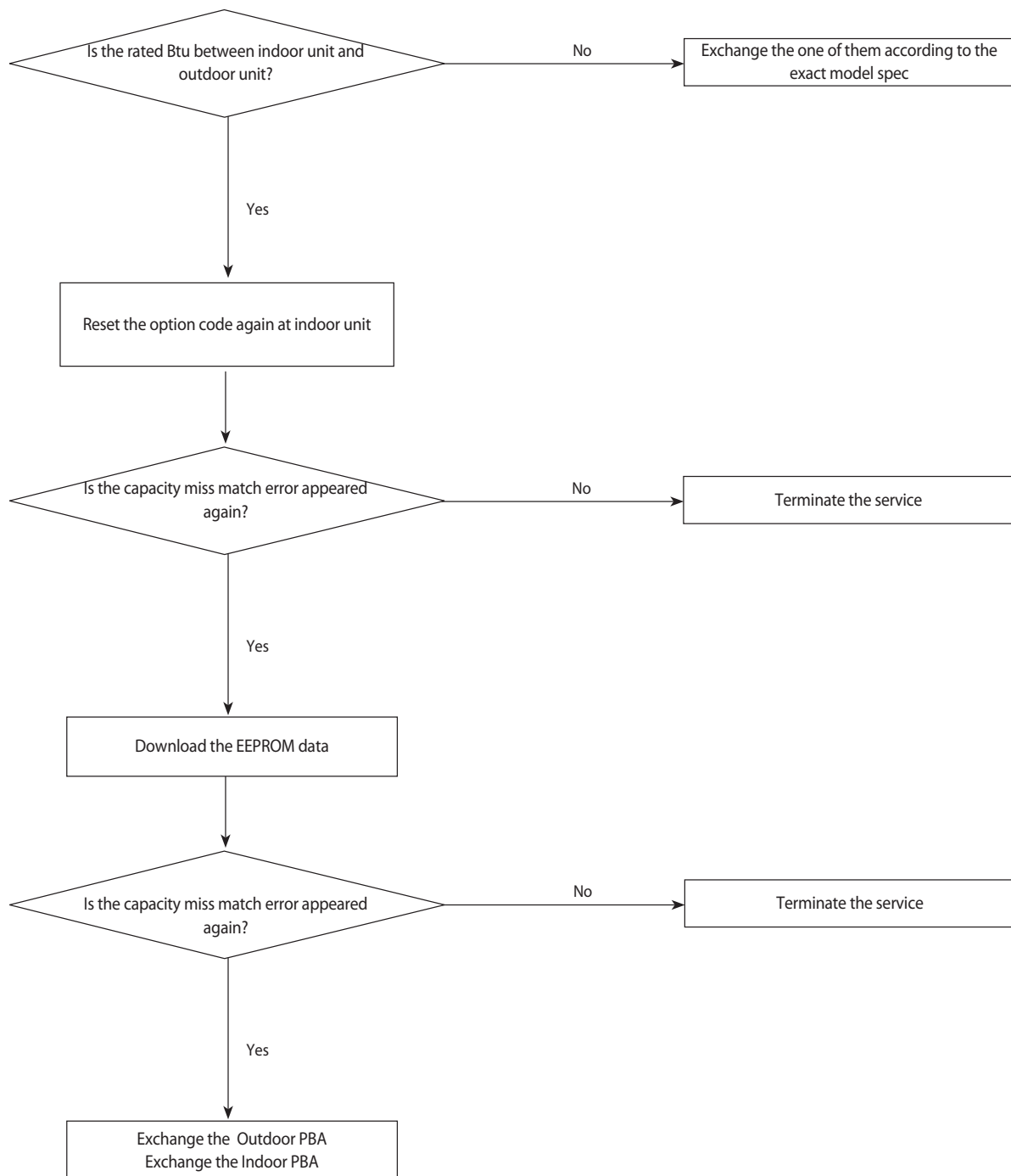

4-4-20 Gas leak error

1. Checklist :

- 1) Is the position of indoor Eva_in sensor normal?
- 2) Check the pipe crack
- 3) Check the EEV valve connection in Outdoor unit
- 4) Check the refrigerant was charged

2. Troubleshooting procedure

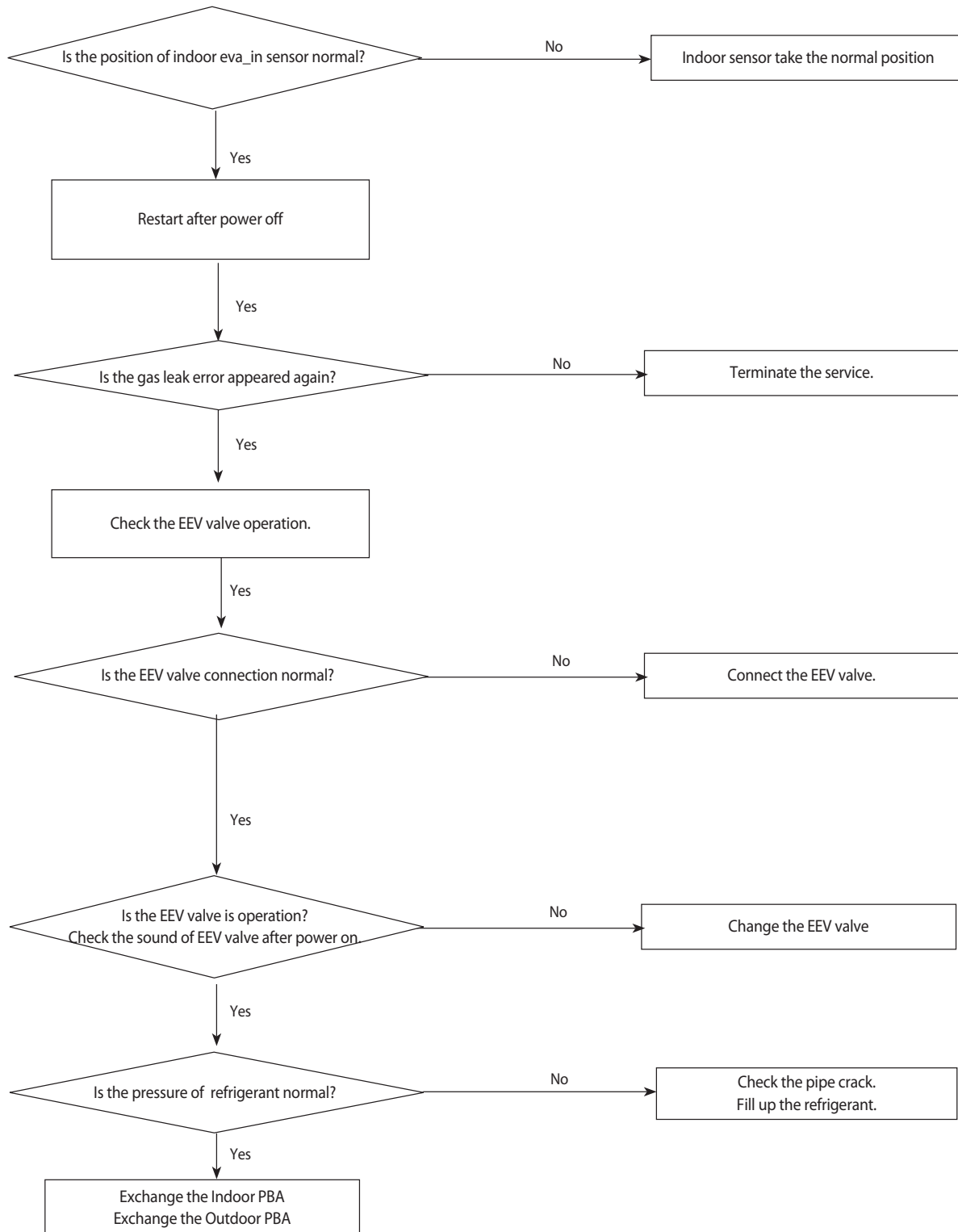

5. PCB Diagram

5-1 Indoor Unit

MAIN PCB

■ AC012MNADCH / AC018MNADCH / AC024MNADCH / AC030MNTDCH / AC036MNTDCH

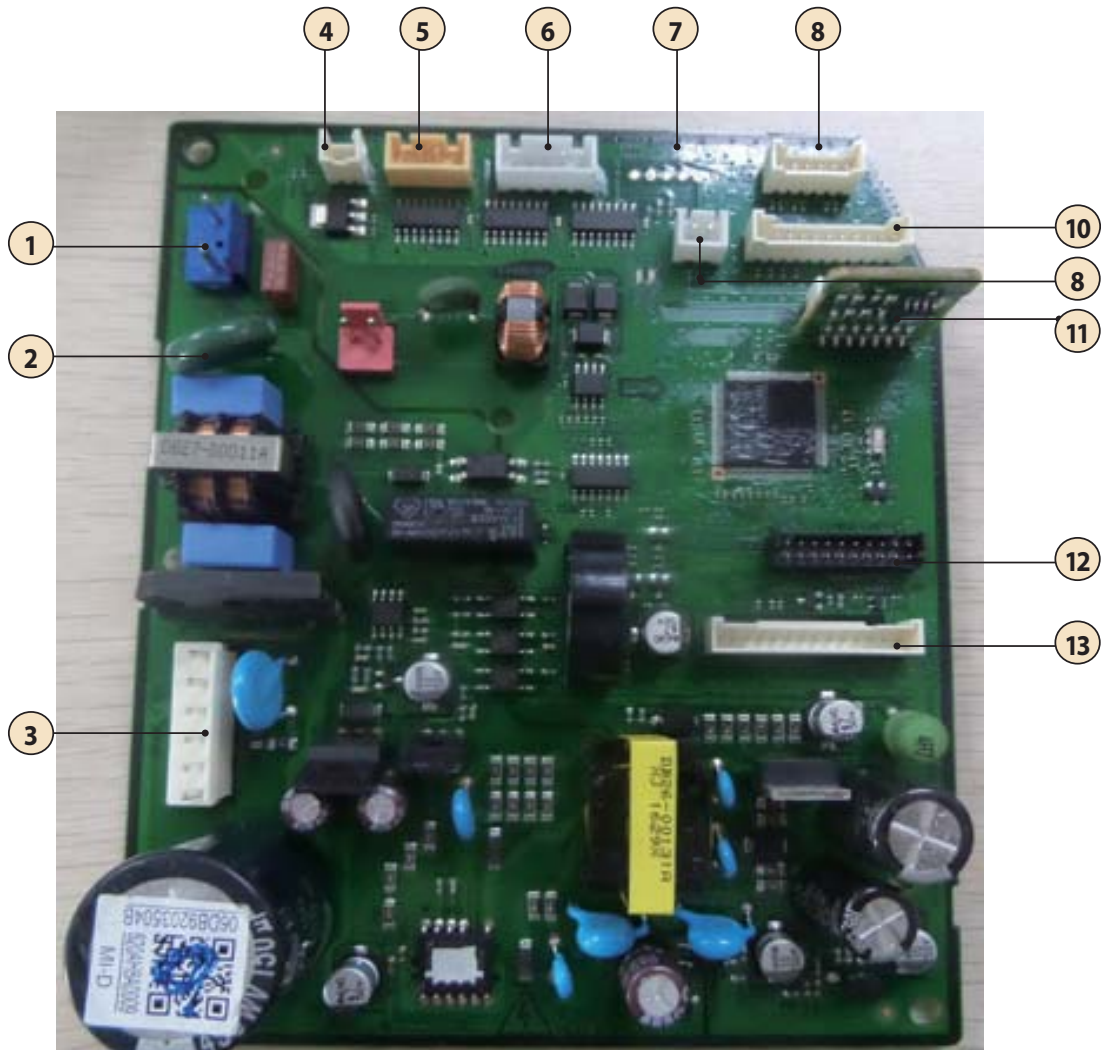

<p>① CNP101-POWER</p> <p>#1 : L #2 : NOT USED #3 : N</p>	<p>② CN303-COM1</p> <p>#1~2 : COMMUNICATION SIGNAL</p>	<p>③ CN701-BLDC FAN</p> <p>#1 : DC 310V #2 : NOT USED #3 : GND #4 : PWM SIGNAL #5 : FEEDBACK SIGNAL</p>	<p>④ CN140-FUSE CHECK</p> <p>#1 : THERMAL FUSE SIGNAL #2 : GND</p>
<p>⑤ CN805-SPI</p> <p>#1~2 : GND #3 : SPI CONTROL SIGNAL #4 : NOT USED</p>	<p>⑥ CN802-STEP UP/DOWN</p> <p>#1 : DC 12V #2~5 : LOUVER SIGNAL</p>	<p>⑦ CN801-EEV</p> <p>#1~4 : EEV SIGNAL #5~6 : DC 12V</p>	<p>⑧ CN401-ROOM</p> <p>#1 : OOM TEMPERATURE SENSOR SIGNAL #2 : GND</p>
<p>⑨ CN403-EVA IN/OUT/DIS</p> <p>#1 : EVA IN TEMPERATURE SENSOR SIGNAL #2 : GND #3 : EVA OUT TEMPERATURE SENSOR SIGNAL #4 : GND #5 : DISCHARGE TEMPERATURE SENSOR SIGNAL #6 : GND</p>	<p>⑩ CN501-DISPLAY</p> <p>#1~3 : LED SIGNAL #4 : REMOCON SIGNAL #5 : GND #6 : DC 5V #7~8 : REMOCON SIGNAL #9~11 : NOT USED</p>	<p>⑪ CN201-EEPROM</p> <p>#1 : GND #2 : NOT USED #3 : DC 5V #4~7 : EEPROM SIGNAL</p>	<p>⑫ CN302-DOWNLOAD</p> <p>#1~8 : DOWNLOAD SIGNAL #9 : GND #10~11 : DC 5V #12~16 : DOWNLOAD SIGNAL #17 : GND #18~20 : DOWNLOAD SIGNAL</p>
<p>⑬ CN301-to 2WIRE SUB</p> <p>#1~2 : COMMUNICATION SIGNAL #3~4 : SUB PBA SIGNAL #5 : EXTERNAL CONTROL SIGNAL #6 : COMP CHECK SIGNAL #7 : ERROR CHECK SIGNAL #8 : DC 5V #9 : GND #10 : DC 12V #11~14 : COMMUNICATION SIGNAL</p>			

■ Sub PCB

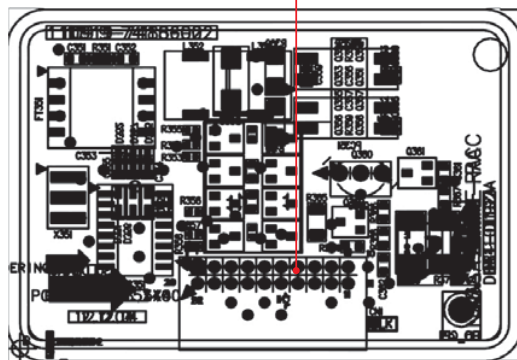
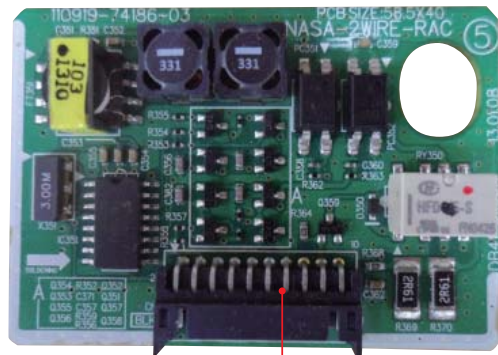

- ① **CN1-2WIRES COMM.**
- #1,#2,#19,#20:COMM. SIGNAL
 - #3,#18:EXTERNAL CONTROL
 - #4,#17:COMP CHECK
 - #5,#16:ERROR CHECK
 - #6:VCC(DC5V)
 - #7,#14:GND
 - #8,#13,#15:DC12V
 - #9~#12:COMM. SIGNAL

5-2 Outdoor Unit

■ AC012KXADCH

Main PCB

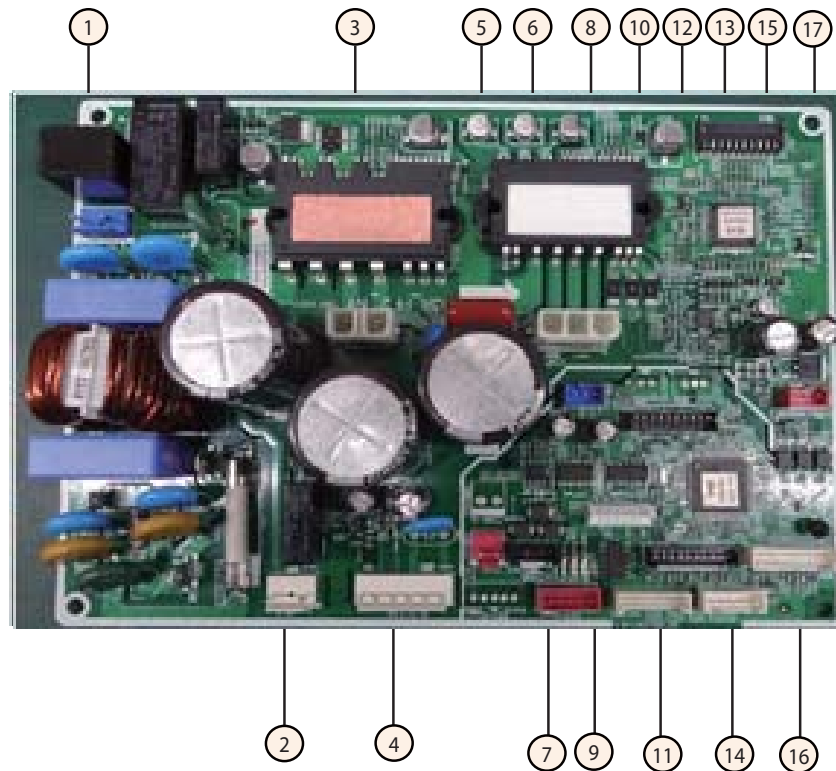

NO	Description
1	SMPS POWER: YW396-03AV BLU
2	4WAY:YW396-03AV WHT
3	REACTOR:DBT081-2P WHT
4	BLDC FAN:YW396-06V WHT
5	COMM:YW396-02V RED
6	SUB PBA POWER:SMW200-05P BLK
7	EEV1:SMW250-05 RED
8	COMP:DBT061-3P WHT
9	SMPS: SMW250-03 BLU
10	EEPROM:B7P-MQ WHT
11	TEMP SENSOR: SMW200-08P WHT
12	MAIN DOWNLOAD:YDW200-20 BLK
13	SUB PBA: SMW200-10P BLK
14	DRED:SMW250-05 WHT
15	INV DOWNDOWN: YDAW200-20TR BLK
16	SUB PBA: SMW200-10P WHT
17	ENABLE CGND: SMW250-03 RED

■ AC018JXADCH

Main PCB

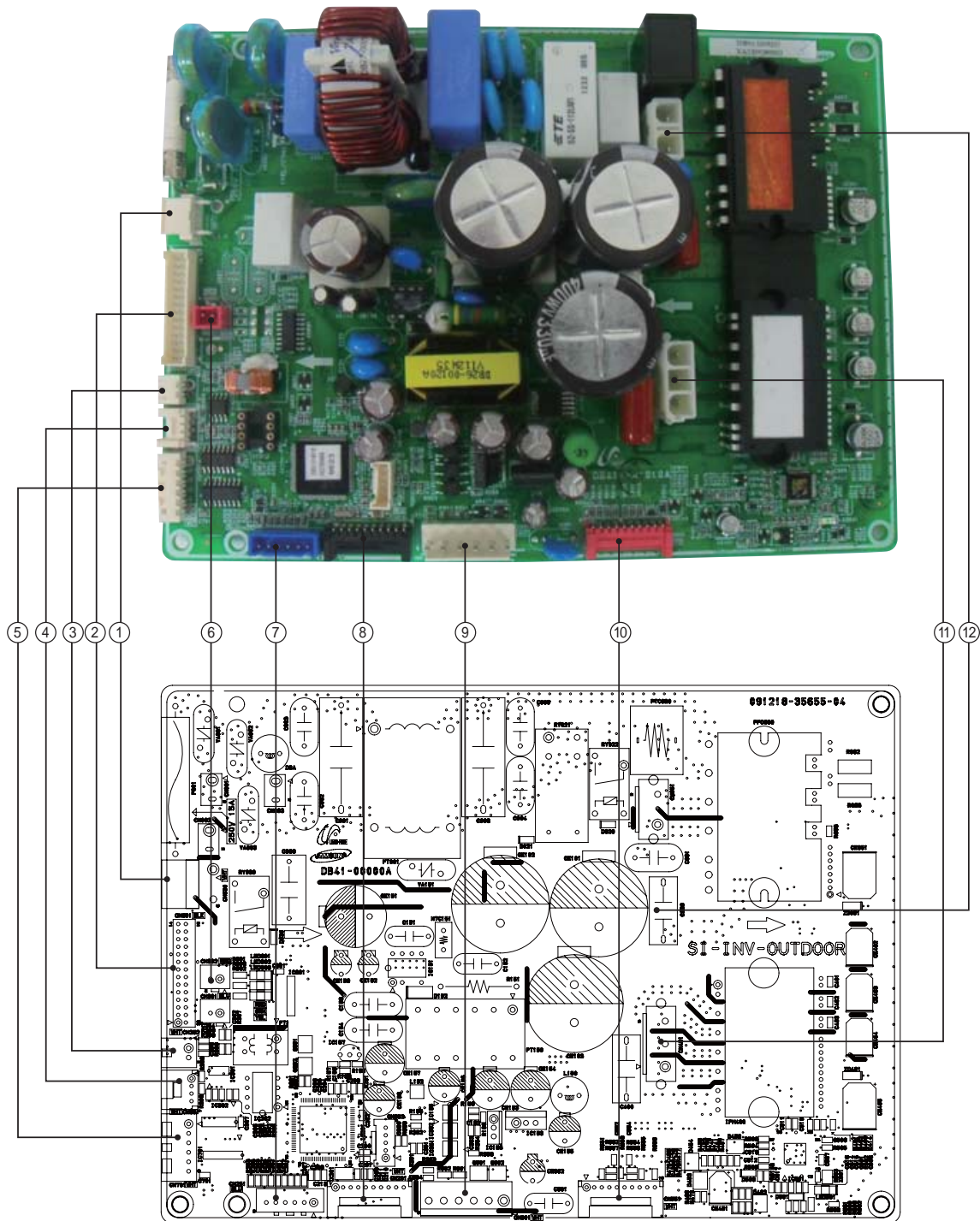

<p>① CN030 : 4WAY VALVE #1~#3 : AC220V</p>	<p>② CN951 : SIGNAL TO SUB PCB #1~#28 : SIGNAL TO SUB PCB</p>	<p>③ CN252 : THERMISTOR #1~#2 : OLP THERMISTOR</p>	<p>④ CN851:S-NET Communication #1 : DC12V #2 : RXD #3 : TXD #4 : GND</p>
<p>⑤ CN701 : EEV #1~#5 : EEV SIGNAL #6 : DC12V</p>	<p>⑥ CN302:Communication(COM1) #1 : COM1(F1) #2 : COM2(F2)</p>	<p>⑦ CN251 : THERMISTOR #1~#2 : OUTDOOR THERMISTOR #3~#4 : DISCHARGE THERMISTOR #5~#6 : COND THERMISTOR</p>	<p>⑧ CN201 : Downloader #1~#10 : Download</p>
<p>⑨ CN901 : BLDC MOTOR #1: DV310V #3: GND #4: DC15V #5: FAN_PWM #6: FAN_Feedback</p>	<p>⑩ CN551: Downloader #1~#10 : Download</p>	<p>⑪ CN451 : COMP POWER #1 : COMP U-Phase #2 : COMP V-Phase #3 : COMP W-Phase</p>	<p>⑫ CN051 : Reactor #1~#2 : Reactor</p>

■ AC018JXADCH

SUB PCB

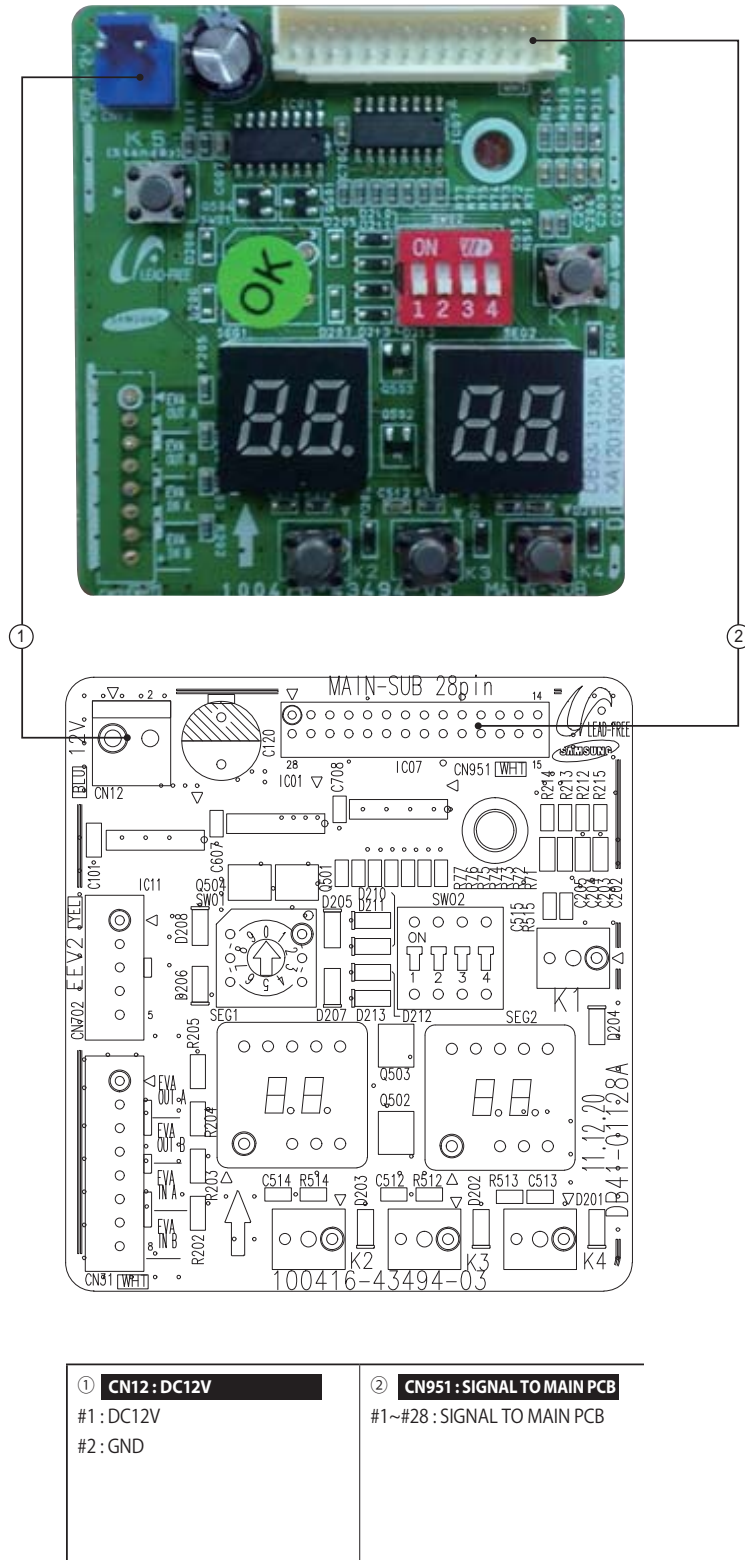

■ AC024JXADCH / AC030JXADCH, AC036JXADCH
MAIN PCB

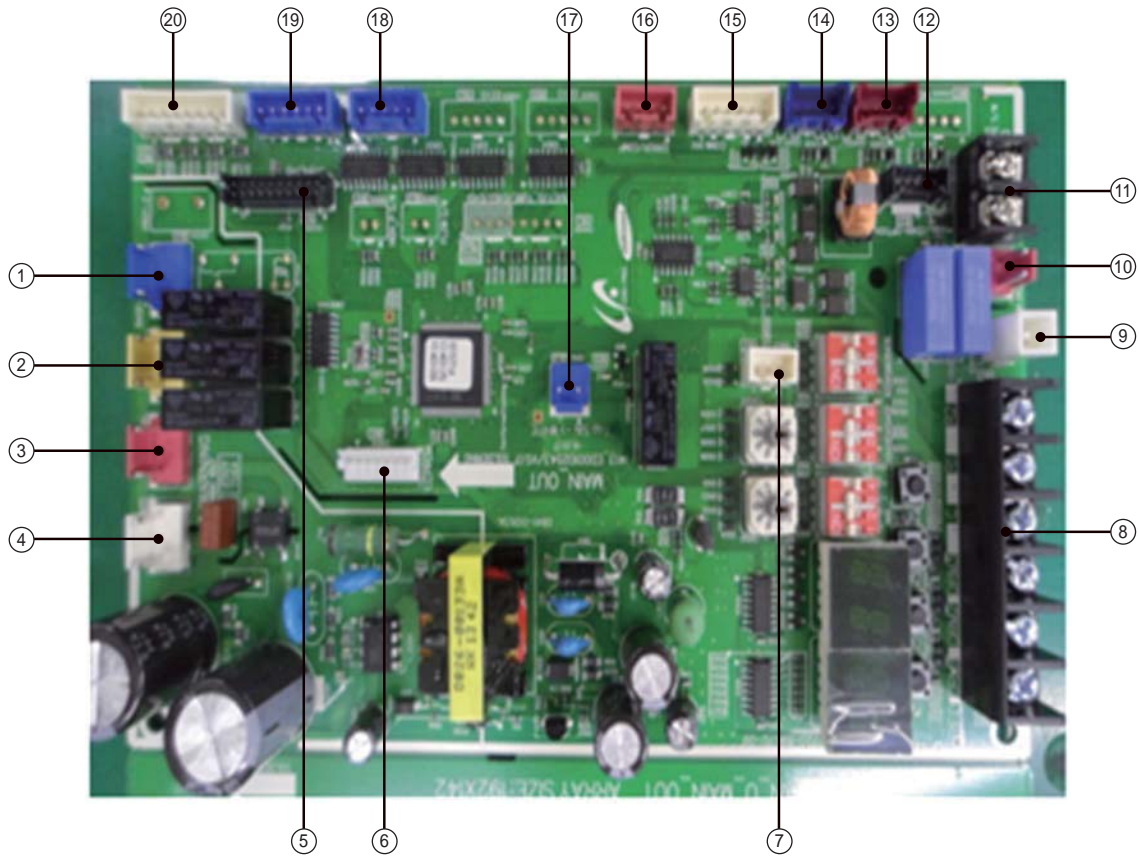

No	Part Code	Local	Function	Description
1	3711-003404	CN703	BASE-HEATER	YW396-03AV BLU
2	3711-003406	CN702	4WAY-1	YW396-03AV YEL
3	3711-003407	CN701	HOTGAS	YW396-03AV RED
4	3711-000203	CN101	POWER	YW396-03AV WHT
5	3711-002001	CN306	DOWNLOAD	YDW200-20P BLK
6	3711-007817	CN806	EEPROM	B7P-MQ WHT
7	3711-000024	CN501	MODE SELECTOR	SMW250-03 WHT
8	DB65-00320A	CN304	DRED	DAPC-2009-6P BLK
9	3711-000744	CN103	EARTH	YDW236-01 WHT
10	3711-000177	CN303	COMM-INDOOR	YW396-02V RED
11	3716-001162	CN003	QUIET S/W	BR-7623-2P BLK
12	3711-005096	CN302	COMM-OPTION	SMW200-05 BLK
13	3711-007069	CN402	HIGH PRESSURE S/W	B04B-XARK-1 RED
14	3711-007325	CN401	LOW PRESSURE S/W	B04B-XARK-1 BLU
15	3711-001038	CN305	COMM INV	SMW250-06 WHT
16	3711-000939	CN801	ERROR/COMP CHECK	SMW250-04 RED
17	3711-000176	CN12	DC12V	YW396-02V BLU
18	3711-000997	CN803	EEV1	SMW250-05 BLU
19	3711-001036	CN802	EEV4	SMW250-06 BLU
20	3711-001084	CN403	OUT TEMP/COND/DISQ/OLP	SMW250-08 WHT

■ AC024JXADCH / AC030JXADCH, AC036JXADCH
INVERTER PCB

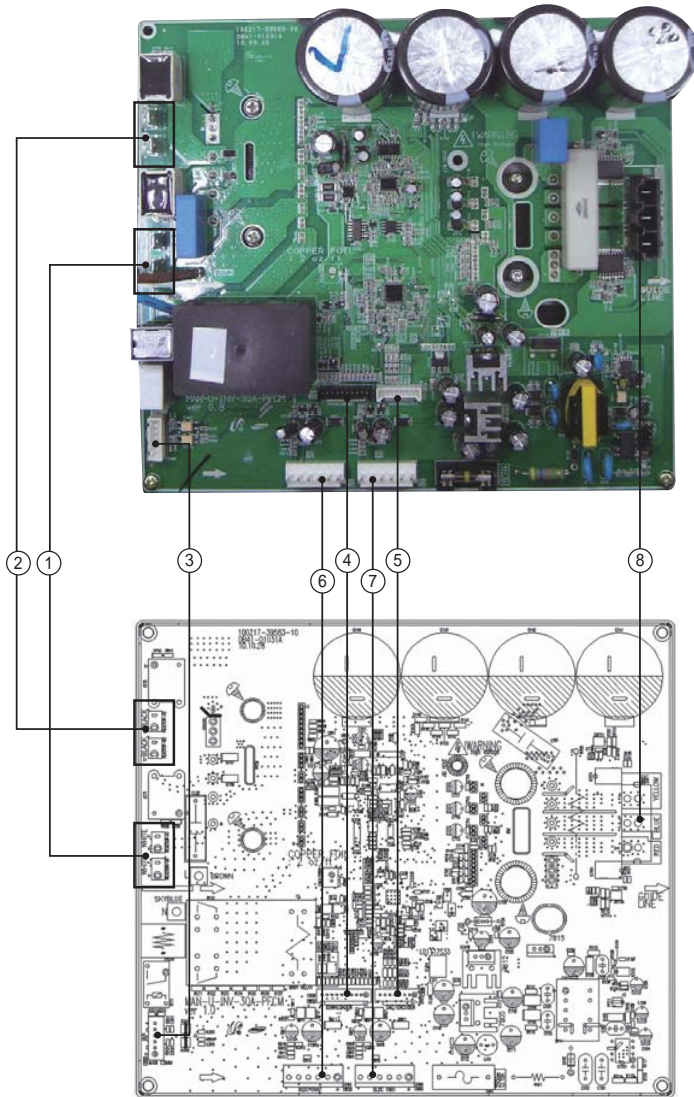

<p>① Reactor-A1/B1 #Reactor-A2 : WHT #Reactor-B2 : WHT</p>	<p>② Reactor-A2/B2 #Reactor-A2 : BLK #Reactor-B2 : BLK</p>	<p>③ CN50(2PIN/RED)-Communication #1 : RXD, #2 : TXD #3 : GND, #4 : DC 5V #5 : DC 12V, #6 : INV. SMPS signal</p>	<p>④ CN22-Downloader #1 : RXD_ATARO, #2 : TXD_ATARO #3, #8 : N.C, #4~#7 : DATA signal #9 : GND, #10 : DC 5V</p>
<p>⑤ CN21-DAC/ENCODER For S/W engineer debugging</p>	<p>⑥ CN91-FAN2 #1 : DC 360V #2 : N.C #3 : GND #4 : DC 15V #5 : FAN RPM #6 : FAN RPM feedback</p>	<p>⑦ CN90-FAN1 #1 : DC 360V #2 : N.C #3 : GND #4 : DC 15V #5 : FAN RPM #6 : FAN RPM feedback</p>	<p>⑧ CN71-COMP. #1 : COMP. U-phase(RED) #2 : COMP. V-phase(BLU) #3 : COMP. U-phase(YEL)</p>

■ AC024JXADCH / AC030JXADCH / AC036JXADCH

EMI PCB

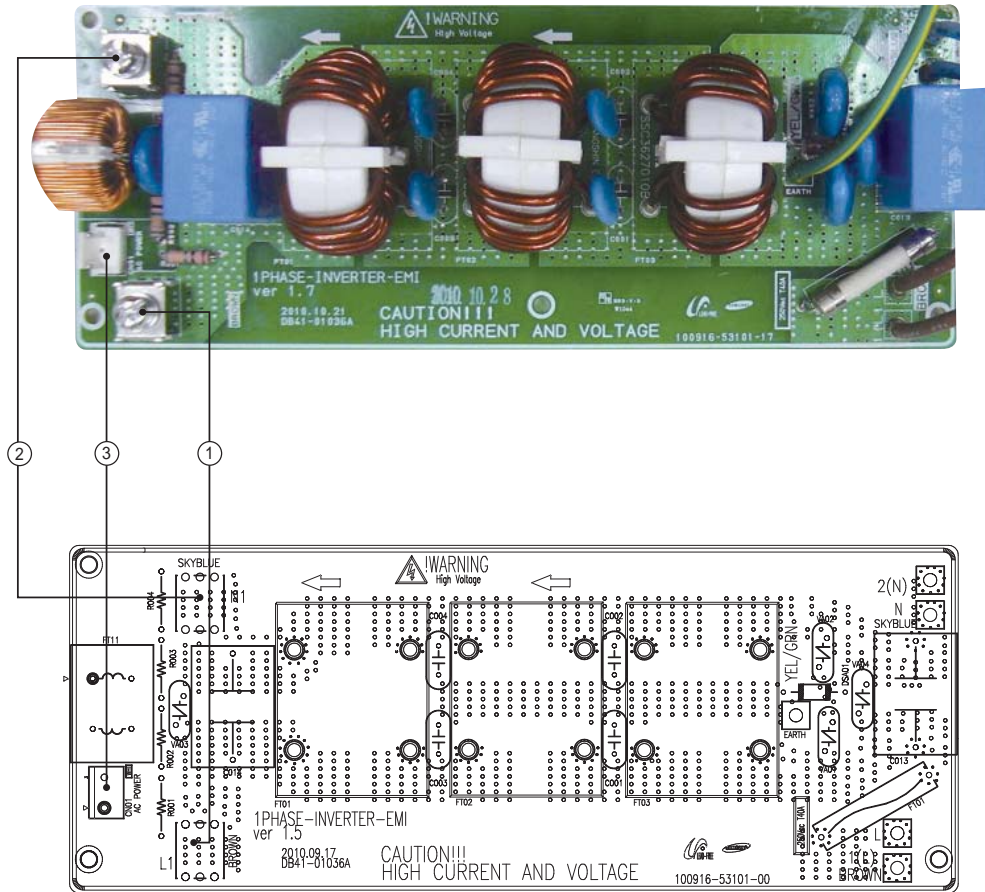

<p>① L1-AC POWER L phase L1 : BRN</p>	<p>② N1-AC POWER N phase N1 : SKY-BLU</p>	<p>③ CN01-AC POWER #1-#3 : AC 220~240V</p>
--	--	---

6. Wiring Diagram

6-1 Indoor Unit

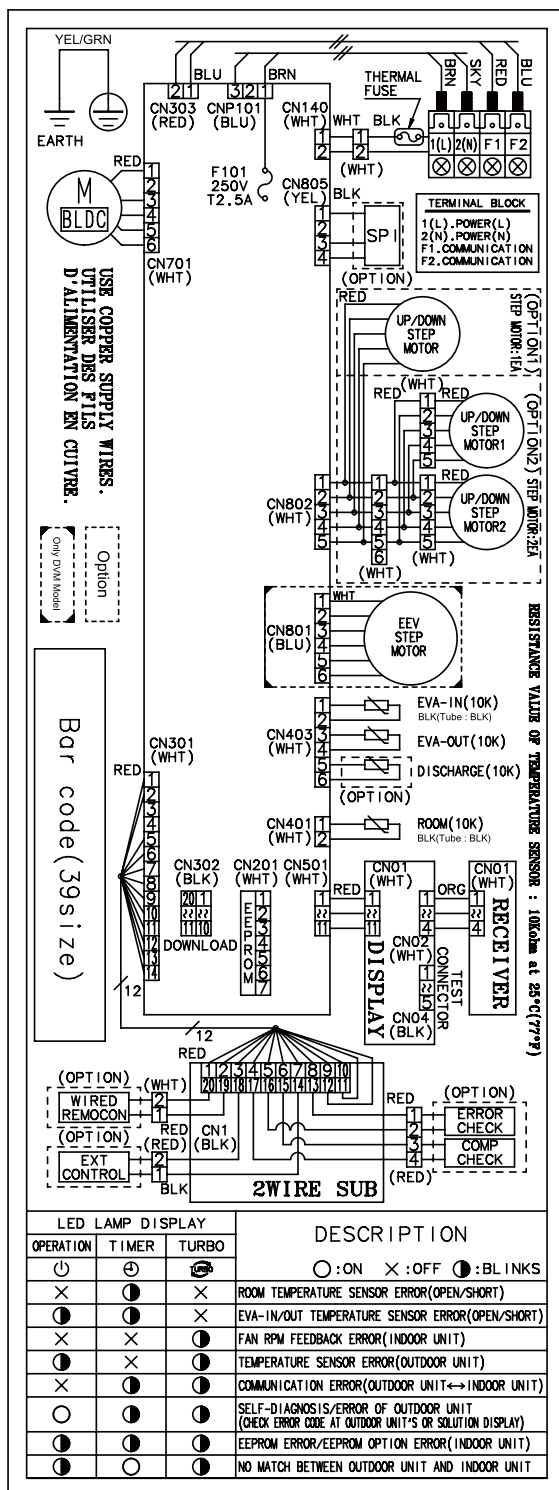

This Document can not be used without Samsung's authorization.

6-2 Outdoor Unit

■ AC012KNLDCH

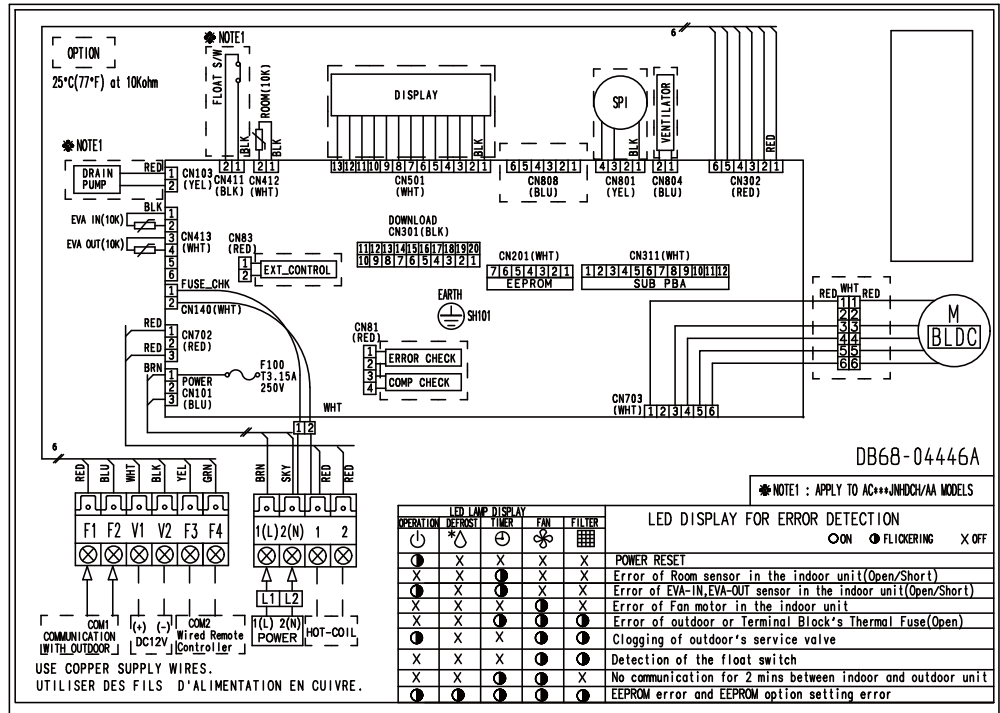

This Document can not be used without Samsung's authorization.

■ AC018JXADCH

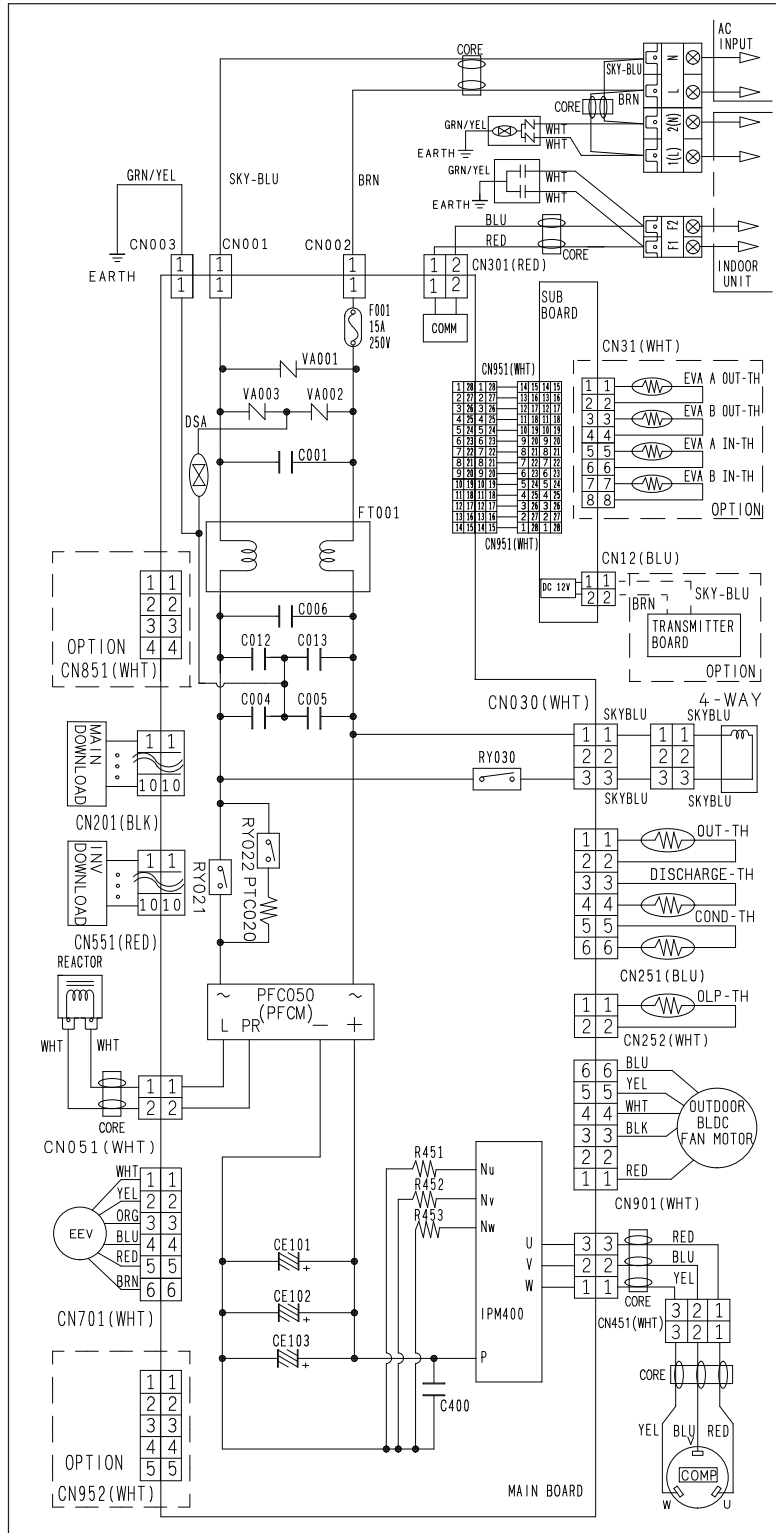

This Document can not be used without Samsung's authorization.

■ AC024JXADCH / AC030JXADCH / AC036JXADCH

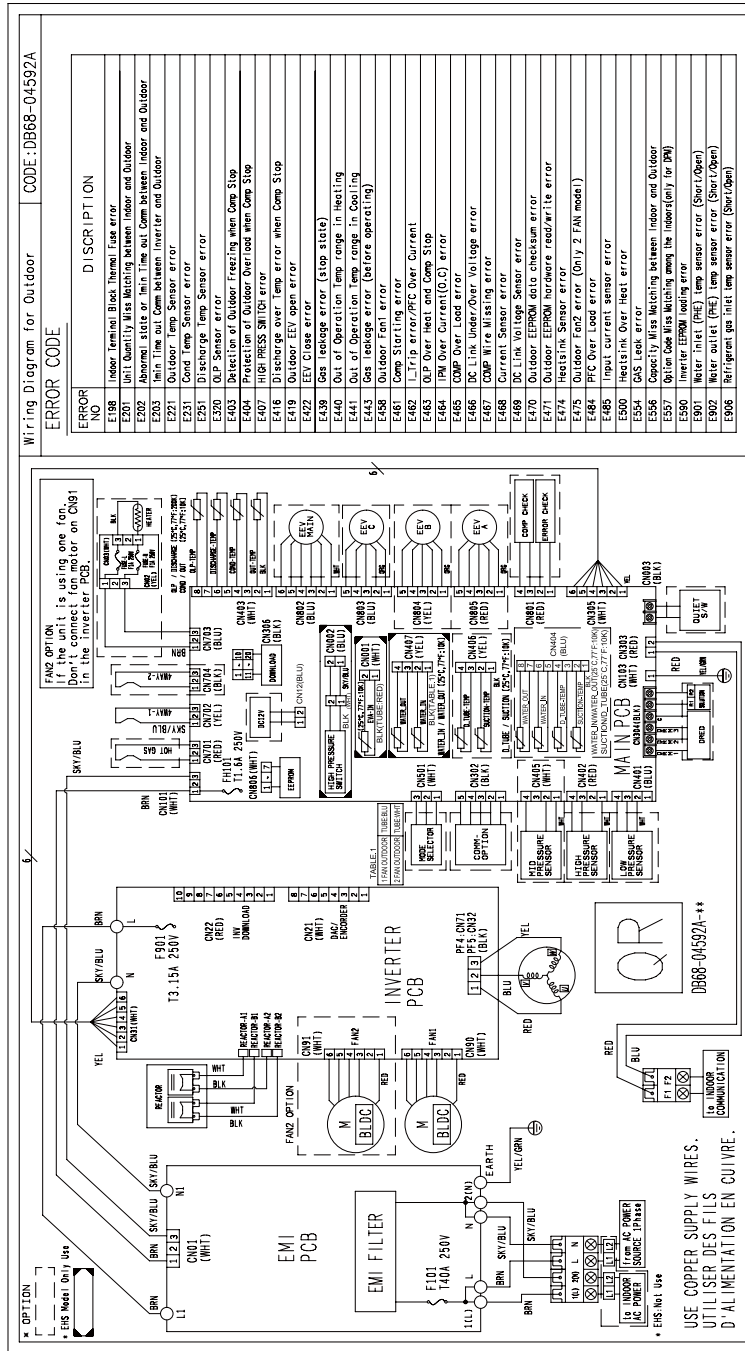

This Document can not be used without Samsung's authorization.

7. Preference Sheet

7-1 Index of Model Name

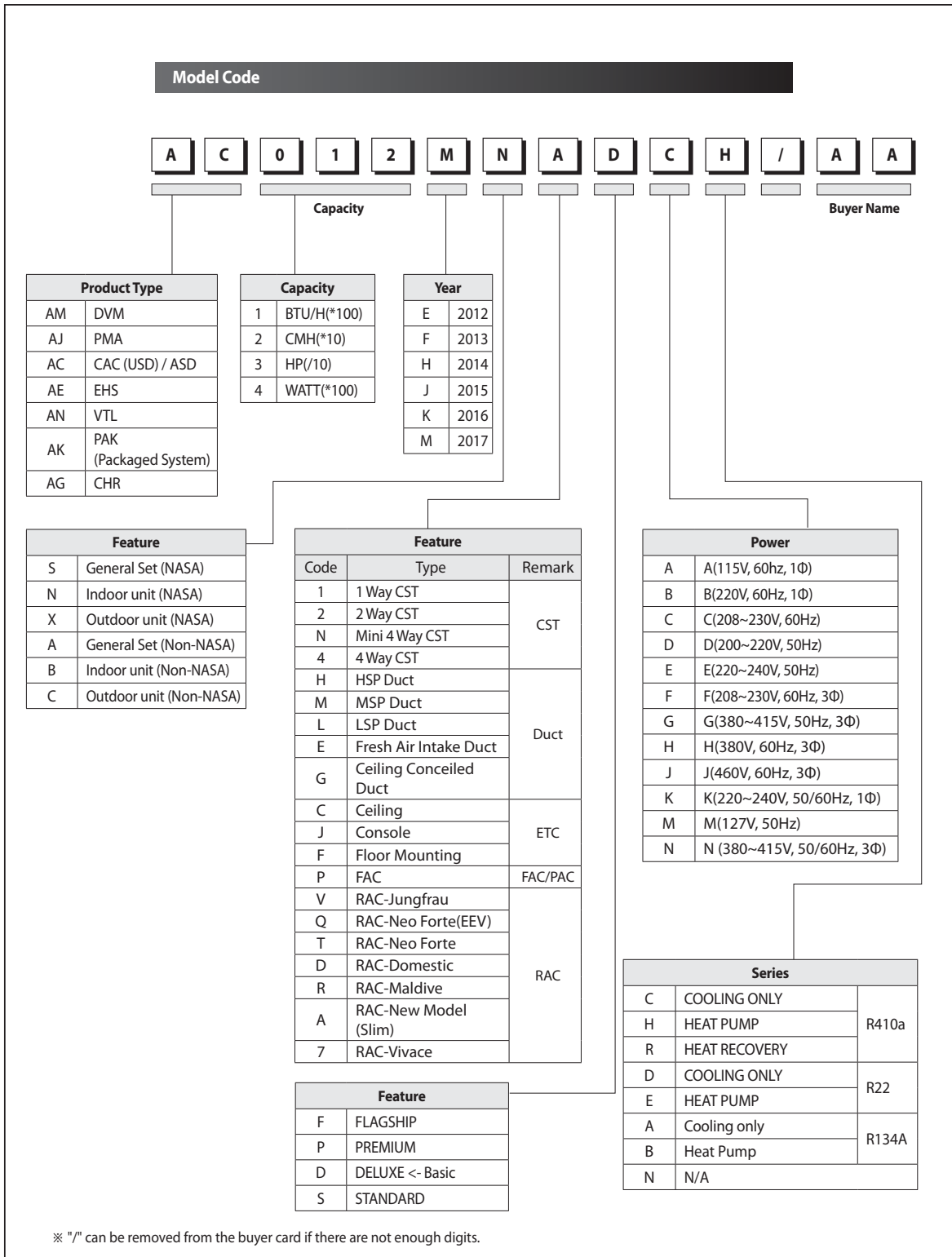

7-2 Refrigerating Cycle Diagram

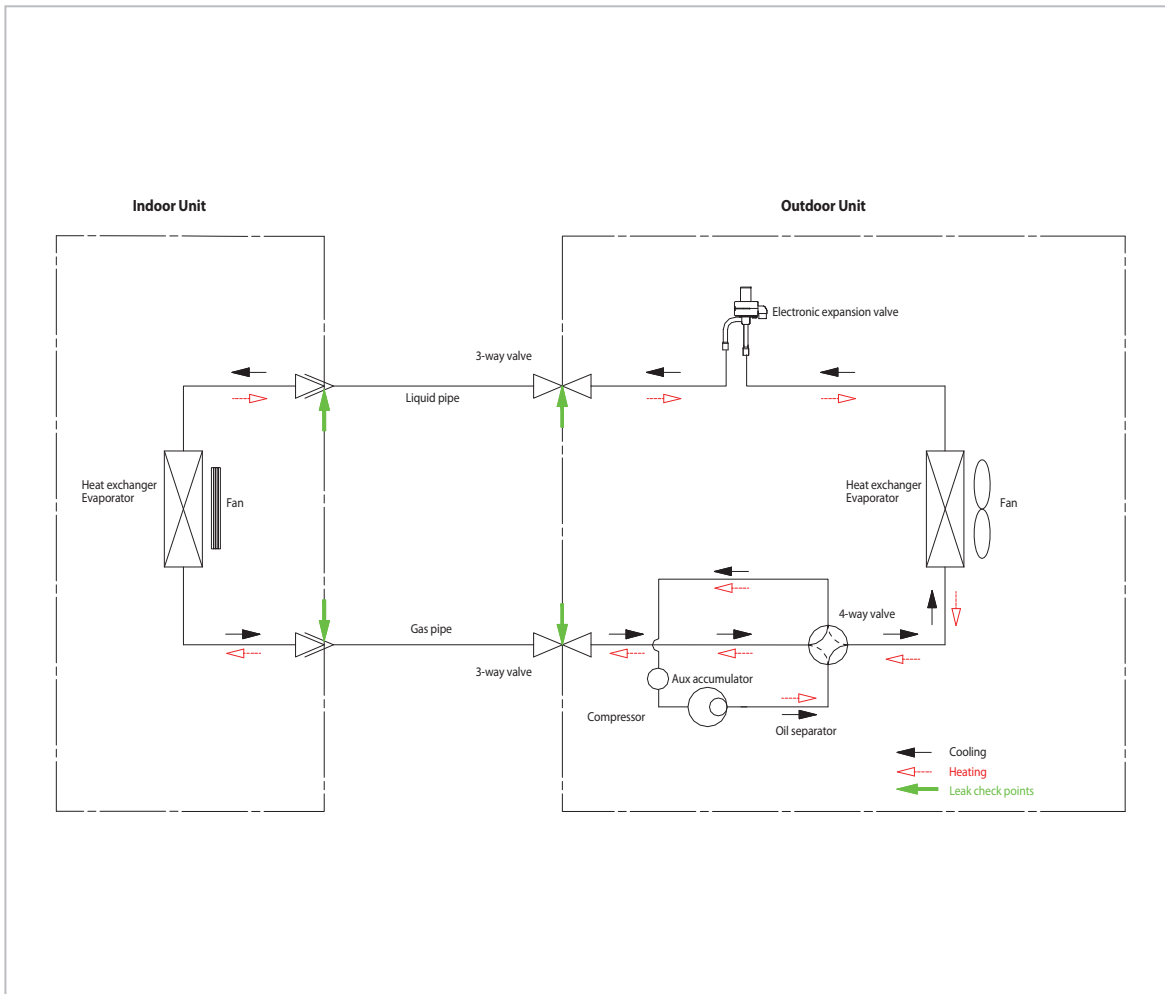

■ CONDENSER

High temperature and high pressure gas state coolant discharged from the compressor is converted to a liquid state as it is cooled down by the heat emission in the outdoor condenser unit, and sent to the evaporator.

■ COMPRESSOR

Low temperature and low pressure coolant is compressed and sent to the cycling system

■ EVAPORATOR

Liquid coolant sucked in through the capillary tubes cools down the room by absorbing the surrounding heat as it evaporates (converting from liquid to gas). (Absorbing heat required for evaporation)

■ SERVICE VALVE

You can open the valve by turning the need valve counterclockwise using hex wrench, and it is used for vacuum, gas purging, coolant injection, coolant purging, and indoor-outdoor unit connection.

■ ACCUMULATOR

Accumulator prevents the flow of liquid-state coolant into the compressor. (Liquid-state coolant flowing into the compressor will overload the compressor.)

SAMSUNG

This Service Manual is a property of Samsung Electronics Co., Ltd.
Any unauthorized use of Manual can be punished under applicable
International and/or domestic law.

© Samsung Electronics Co., Ltd. Mar. 2017.
Printed in China.