

Goldleaf  *Scientific*

Instruction Manual

Flow-Through-Chamber DK 40

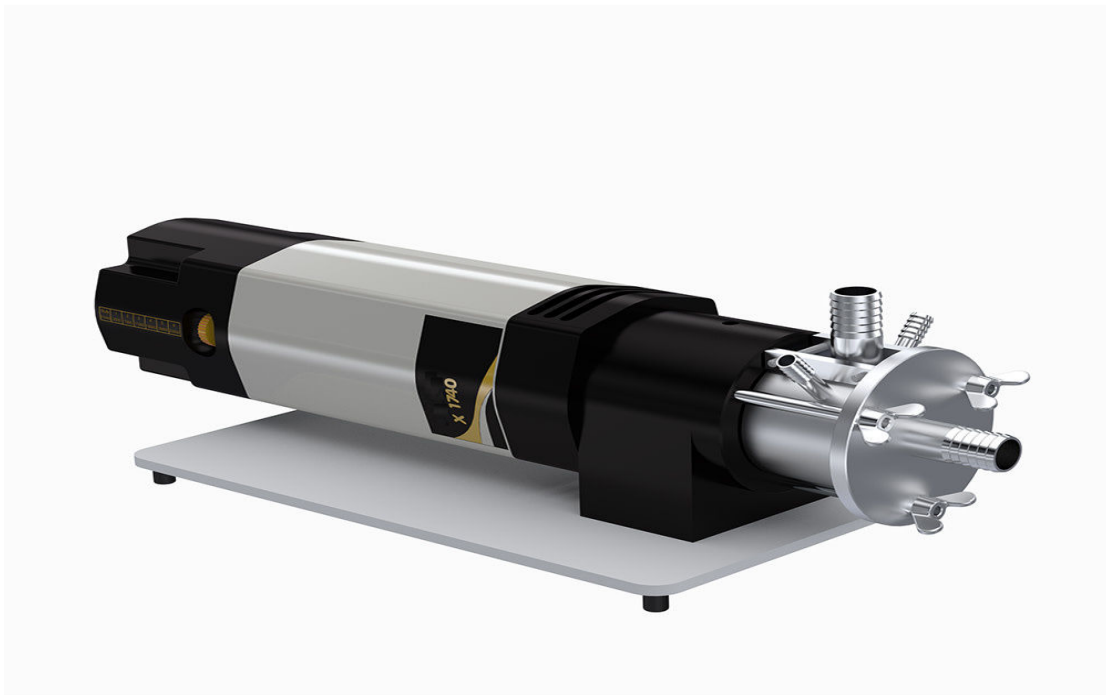

(Shown with drive X 1740, Not included)

Content

1	User Instructions	4
1.1	Important Instructions for your safety	4
1.2	Danger symbols in this operating manual	5
1.2.1	Danger symbols:	5
1.2.2	Danger levels	5
1.2.3	Warning signs on the device	5
2	General safety warnings and instructions	6
3	Unpacking the Instrument	7
3.1	Scope of delivery	8
3.2	General Safety Information	8
3.3	Intended Use	8
3.4	Description of a homogenising tool	9
4	Assembling the DK 40 Flow-Through-Chamber	9
4.1	Description of DK 40 Flow-Through-Chamber	9
4.2	Mounting the Flow-Through-Chamber	10
4.3	Mounting the Flow-Through-Chamber to the Drive Unit X 1740	12
5	Operation of Flow Through-Chamber	13
5.1	Flow-Through Mode	13
5.2	Circulation Mode	13
6	Maintenance and Cleaning	13
6.1	Cleaning the homogenising tool	13
6.2	Rough Cleaning of Flow-Through-Chamber and Tubing	13
6.3	Cleaning the Inside of the Flow-Through-Chamber and Generator	14
6.3.1	Disassembling Shaft G 40 for DK40	15
6.3.2	Disassembly of bearing at the bottom of the shaft G 40	15
6.4	Maintenance of drive unit X 1740	16
6.5	Maintenance homogenizing tools	16
7	Dismantling, Transport and Storage	16
7.1	Dismantling	16
7.2	Transport and Storage	16
8	Disposal	17
9	Warranty and Liability	17
10	Technical Data	17
11	Repairs	17
11.1	Repair Return Form	18

1 User Instructions

1.1 Important Instructions for your safety



before use.

- Every user must read and understand this manual completely. Failure to do so can result in serious injury or death.









- Comply with all safety and accident-prevention regulations applicable to laboratory work.
- Follow general instructions for hazard prevention and general safety instructions, e.g. wear protection clothing, eye protection and gloves.
- This operating manual is part of the product. Thus, it must always be easily accessible.
- This instruction sheet does not purport to address all of the safety problems which might result from the use of this device, chemicals, reagents, apparatus or equipment employed in any specific test or protocols. It is the responsibility of the user to consult their authorized safety advisors and establish appropriate health and safety practices and then determine the application of regulatory limitations prior to use.
- Enclose this operating manual when transferring the device to another place.
- If this manual is lost, please request another one. Please contact your dealer or:

Goldleaf Scientific
3300 Harrison st suite 2
Riverside CA 92503
www.goldleaflabs.com
support@goldleaflabs.com





1.2 Danger symbols in this operating manual

The safety instructions in this manual appear with the following danger symbols and danger levels:

1.2.1 Danger symbols:

 Hazard point	 Electrical shock
 Risk of fire	 Explosion
 Crushing	 Bio hazard
 Chemical hazard	 Material damage

1.2.2 Danger levels

 DANGER	Will lead to severe injuries or death
 WARNING	May lead to severe injuries or death
 CAUTION	May lead to light to moderate injuries
 NOTICE	May lead to material damage



1.2.3 Warning signs on the device







WARNING

This symbol indicates that it is imperative to read and understand the instruction manual prior to operating the instrument. Please highlight points which require special attention in your field of application so they are not overlooked. Disregard of warnings may result in impairment of serviceability as well as in physical harm to the user.

2 General safety warnings and instructions

	<p>⚠ DANGER Risk of explosion.</p> <ul style="list-style-type: none">• Do not operate the device in the vicinity of highly flammable or explosive substances. The instrument is not explosion-proof.• Do not use this device for processing any substances which could generate an explosive atmosphere.• Do not use this device to process any explosive or highly reactive substances.• Do not use flammable or explosive substances near the instrument.
	<p>⚠ WARNING Damage to health due to corrosive or aggressive chemicals</p> <ul style="list-style-type: none">• Observe all markings on the reagent bottles.• Always check the instrument for leaks and air bubbles. Special attention should be directed to determine that all push-ons, threaded connections and suction tubes are firmly in place before beginning operation. <p>Leaking solutions may endanger persons and materials</p> <ul style="list-style-type: none">• Use proper connecting vessels, protective clothing and gloves.• Avoid splashes• When dispensing, maintain a physical distance between the instrument and the body.• Dangerous and fuming chemicals must be dispensed in a fume hood.• Only employ the instrument for the purpose intended by the manufacturer, and particularly within the resistance limits of the instrument. If in doubt, contact your supplier, or the manufacturer's factory representative at the phone number shown at the front page of this operating instruction.• Always use the instrument in such a manner that neither the operator, nor any other person is endangered.
	<p>⚠ WARNING Damages to health due to infectious liquids and pathogenic germs.</p> <ul style="list-style-type: none">• When handling infectious liquids and pathogenic germs, observe the national regulations, the biological security level of your laboratory, the material safety data sheets and the manufacturer's application notes.• Wear personal protective equipment• For comprehensive regulations about handling germs or biological material of the risk group II or higher, please refer to the "Laboratory Biosafety Manual" in its respectively current valid version from the World Health Organisation

	<p>▲WARNING Damage to health due to contaminated device and accessories</p> <p>In the following cases, sample material can be released:</p> <ul style="list-style-type: none"> - unstable tubes - smashed glass tubes - too high speed causes splashes <ul style="list-style-type: none"> ● Only mix in stable tubes ● Observe the nationally prescribed safety environment when working with hazardous, toxic and pathogenic samples. Pay particular attention to personal protective equipment (gloves, clothing, goggles, etc.), extraction, and the safety class of the lab. ● Decontaminate the device and the accessories before storage and shipping.
	<p>▲WARNING Risk of fire</p> <ul style="list-style-type: none"> ● Do not use this device to process any highly flammable liquids
	<p>▲CAUTION Poor safety due to inadequate fixing of the unit</p> <ul style="list-style-type: none"> ● Ensure that the unit is firmly attached to a solid stand.
	<p>▲CAUTION Poor safety due to incorrect accessories and spare parts.</p> <p>The use of accessories and spare parts other than recommended by Ingenieurbüro Goldleaf Scientific may impair the safety, function and precision of the device. Goldleaf Scientific cannot be held liable or accept any liability for damage resulting from the use of incorrect or non-recommended accessories and spare parts, or from the improper use of such equipment.</p> <ul style="list-style-type: none"> ● Only use accessories and spare parts recommended by Goldleaf Scientific
	<p>▲CAUTION Crush hazard due to moving parts</p> <ul style="list-style-type: none"> ● Do not replace any consumables as long as the device is running. ● Do not open the coverage as long as the device is running

3 Unpacking the Instrument

Unpack the instrument carefully and check to see that it is not damaged. It is important that any damage incurred in transport to be recognized at the time of unpacking. Notify your carrier or forwarding agent immediately in case of such damage.

3.1 Scope of delivery

Please check that the package contains the following:

DK 40 incl. baseplate PN: 60429-000N or 60429-000V or 60429-000F (generator type N/V/F)

Cross handle screw M6x30 PN: 00428-0055

Instruction Manual

Accessories (to be ordered separately):

Socket wrench for all shafts PN: 60471-0000

Rotor wrench for shaft T 40 PN: 60477-0000

3.2 General Safety Information



▲WARNING If noise level exceeds 85 dB (A) at the work station operator must use ear plug and/or ear mufflers.



▲WARNING Wear ear protection should the noise level exceed 85dB(A).



▲WARNING Ensure that the unit is firmly fixed.



▲WARNING Wear eye protection.



3.3 Intended Use

The Flow-Through-Chamber DK 40 is a homogenizing system which in connection with the Drive Unit X 1740 produces emulsions and dispersions and is used in laboratories, universities and industries. For safe operation the unit has to be fixed to a stand.

3.4 Description of a homogenising tool



CAUTION

The generators have sharp edges. Handle with care. Risk of injuries!

The homogenizing tool comes always assembled. The connecting adapter (drive pin (10)) is located on the top of the shaft and is used to attach the shaft to the drive motor.

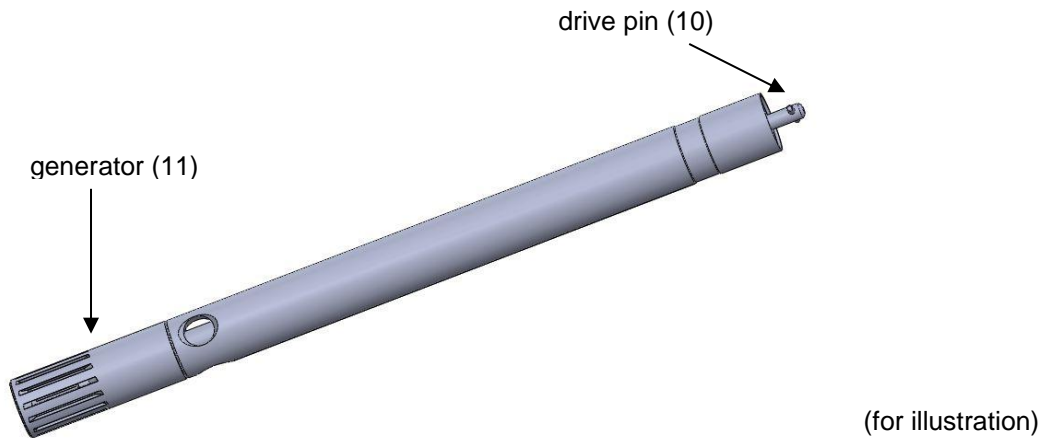

4 Assembling the DK 40 Flow-Through-Chamber

4.1 Description of DK 40 Flow-Through-Chamber

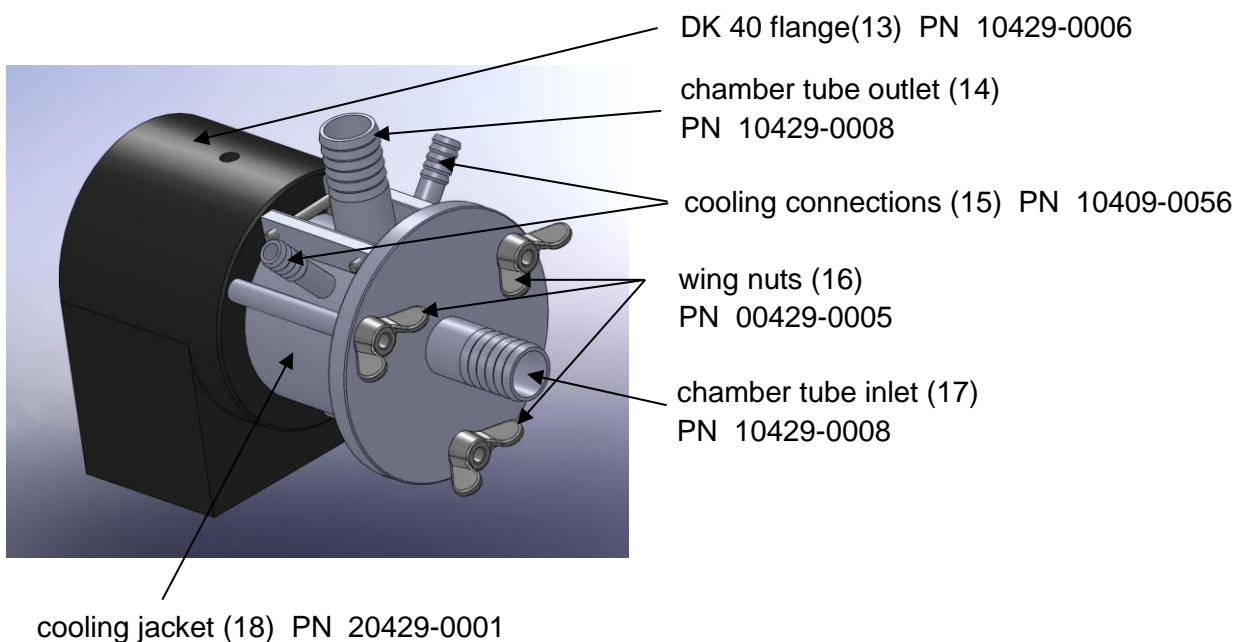

(not illustrated: baseplate)

4.2 Mounting the Flow-Through-Chamber

Take care to avoid damage of parts during assembling respectively disassembling.

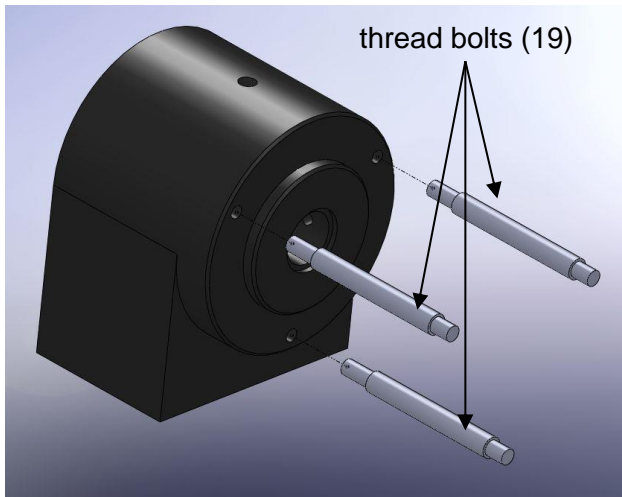

Screw in the 3 thread bolts (19).
PN 10429-0002

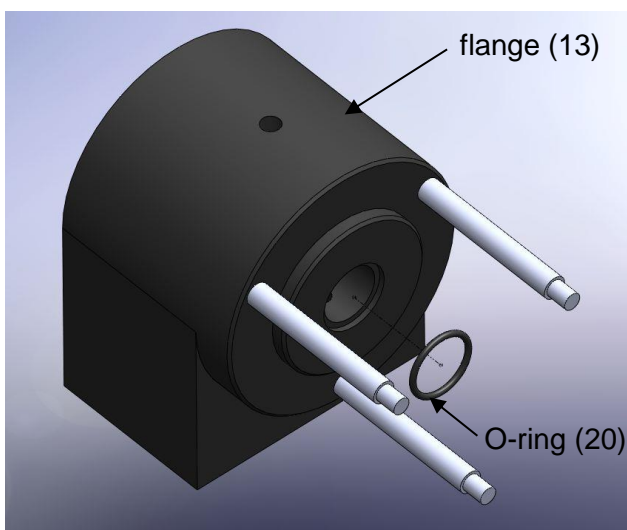

Attach the O-ring (20).
PN 20428-0064

Take care to uniformly press
the O-ring (20) to flange DK 40
(13).

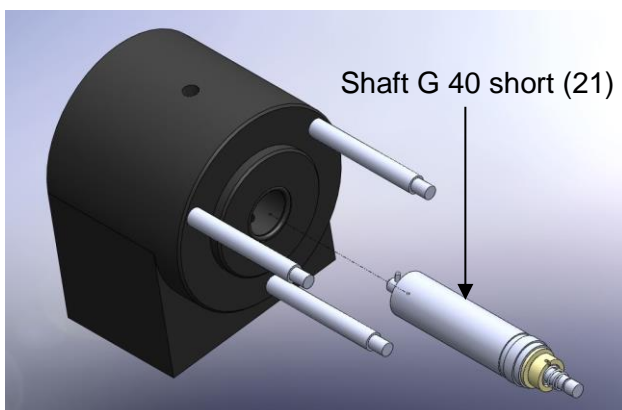

Now insert shaft G 40 (21),
PN 50429-0000
into the DK 40

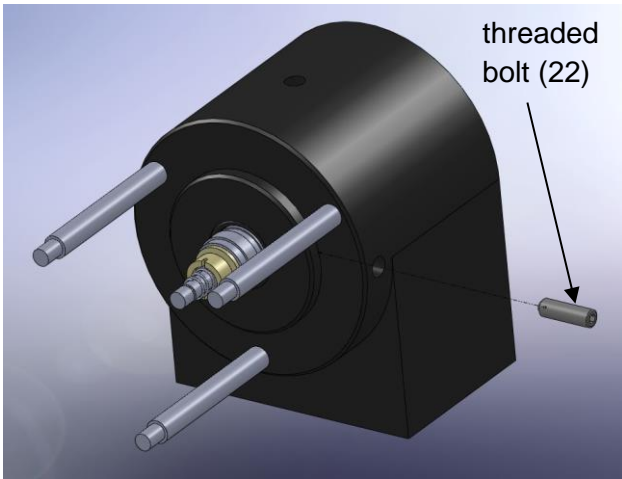

Secure the shaft with threaded bolt (22) PN 00429-0003

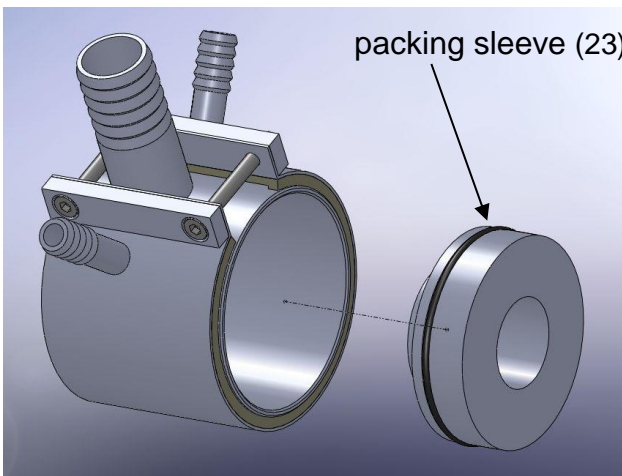

Attach the packing sleeve (23) 10429-0023

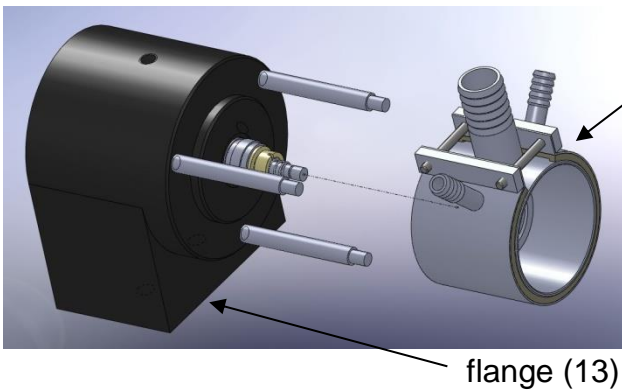

cooling jacket (18) PN 10429-0010

Turn the cooling jacket (18) and attach it to the flange of DK 40 (13) PN 10429-0006

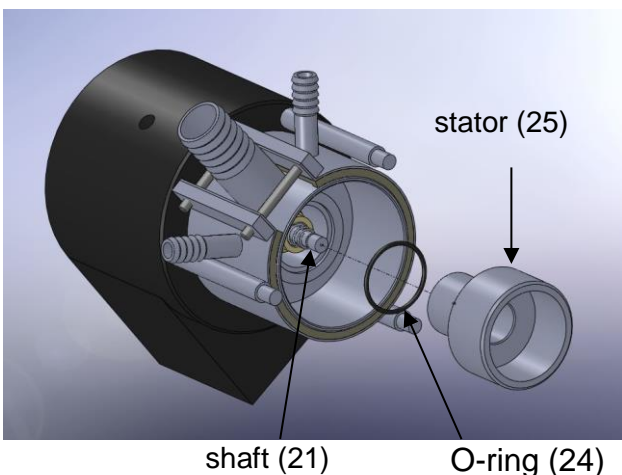

Insert O-ring (24) PN 20429-0003 and then screw the stator (25) PN 60456-0000 to the shaft (21).

Attention: **left-hand thread!**

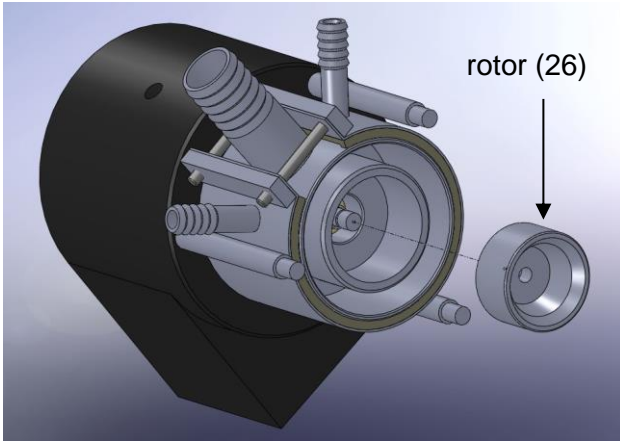

Now attach rotor (26)
PN 60467-0000.

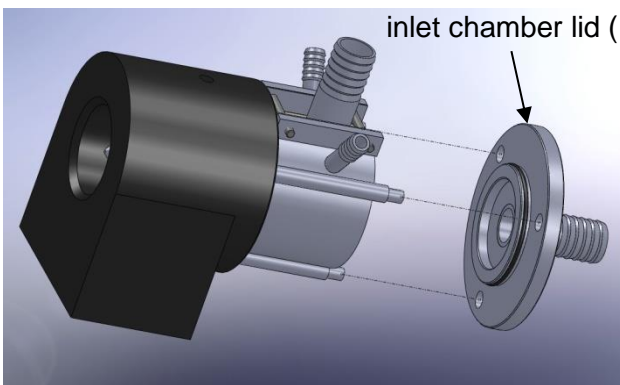

Attach inlet chamber lid (17)
PN 10429-0004

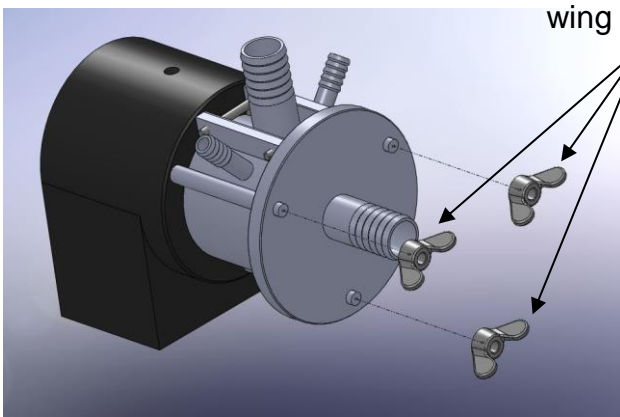

Secure inlet chamber lid (17)
PN 10429-0004
with the 3 wing nuts (16).
PN 00429-0005

4.3 Mounting the Flow-Through-Chamber to the Drive Unit X 1740

Push motor flange of the X 1740 into the flange of DK 40 (13). Turn the motor slightly back and forth until you feel that the motor is properly attached to the flow through chamber.



NOTICE

The drive unit is firmly attached as soon as the wider part of the motor flange fits tightly to the flange of the DK 40 (13)

Turn the drive unit that way that the cooling slots at the motor flange show downwards.

Now fix the drive unit and flow-through-chamber with the help of the fastening screw (X 1740).

5 Operation of Flow Through-Chamber

5.1 Flow-Through Mode

Connect the vessel containing the media to the inlet by a tube (inner diameter = 20 mm).
Connect another tube (inner diameter = 20 mm) to the outlet and lead it to a collecting basin.

Note: Secure all tube connections with suitable tube clips.

5.2 Circulation Mode

Connect in and outlet tube as described in 6.1 and lead the outlet tube back into the original vessel. This way the medium might flow several times through the in-line unit.

NOTICE	The flow-through-chamber is not self-priming. Always fill inlet tube and flow through chamber with a medium. We therefore recommend to set up the vessel containing the sample at the same height as the flow through chamber. Additionally fit a blockage (for example a ball valve) to the connecting tube.
---------------	---

6 Maintenance and Cleaning

6.1 Cleaning the homogenising tool

**CAUTION**

The generators have sharp edges. Handle with care. Risk of injuries!

To avoid clogging clean shaft, generator and in case of G-shaft the sealing parts after each use. This is done by operating it in a solvent which dissolves substance residues and is not harmful to the gasket. This is usually sufficient to clean the generator.

Chemical sterilization may be also a method. General-purpose disinfectants such as formalin, alcohol, etc. may be used. It is important to remove disinfectant residues with sterilized water.

NOTICE

Make sure that the bearings, O-rings and gaskets are resistant to solvents.

Sterilization with moist heat:

This denotes the use of a steam jet pressurized to 2 bars at 120°C.

6.2 Rough Cleaning of Flow-Through-Chamber and Tubing

Flow-through-chamber and tubing might be roughly cleaned by pumping a suitable liquid through the chamber instead of the medium.

6.3 Cleaning the Inside of the Flow-Through-Chamber and Generator

- Disconnect first drive unit X 1740 from the mains
- Detach the flow through chamber from the drive unit
- The flow-through chamber can be disassembled without disconnecting the tubes.
- Remove wing nuts (16, see Chapter 4) together with the washers.
- Now remove inlet lid (17). **Caution: Rest liquid escapes!!!**
- To loosen the rotor (26) you need the rotor wrench for shaft G40 plus the socket wrench for shaft G40.

Note: The wrenches have to be ordered as accessories.

- Push the socket wrench over the drive pin (10, see Chapter 3.4) and hold the socket wrench in this position.
 - Insert the rotor wrench in the rotor and unscrew the rotor by turning to the left.
 - Loosen the stator (25) by turning to the right and take it out. **Note: Left hand thread.**
 - The outer part of the slip ring sealing can now be taken out and cleaned.
-
- Please note the right sequence: Rotating slip ring (A), O-Ring (B), pressing disc (C) and pressing spring (D).

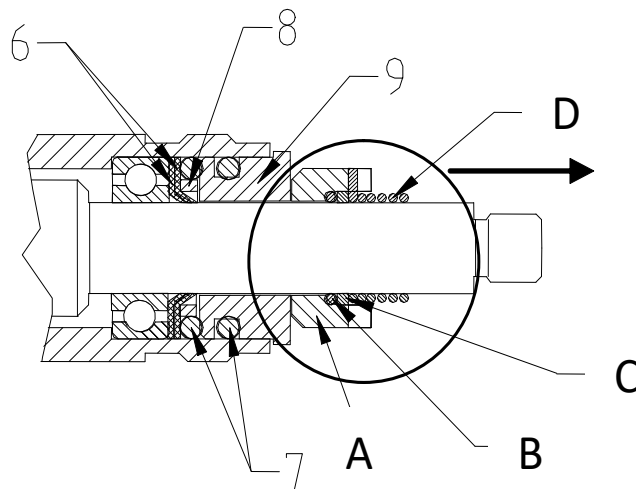

- Now pull off the pipe of the cooling chamber with the chamber tube outlet (14) from packing sleeve (23).

Re-Install the flow chamber in the reverse order of removal.

Please take care that neither O-rings nor any other parts experience any damage during assembling respectively disassembling the flow-through chamber.

NOTICE

Before operation check the slip ring sealing. The slip ring should be easily turned by hand. If it is stuck after a long period without use just loosen slip ring by wetting it with water. Never operate the flow-through chamber if the slip ring is stuck!

Note: Always unscrew the rotor before the stator.

Note: Rotor and stator wrenches are listed in the price list under accessories.

6.3.1 Disassembling Shaft G 40 for DK40

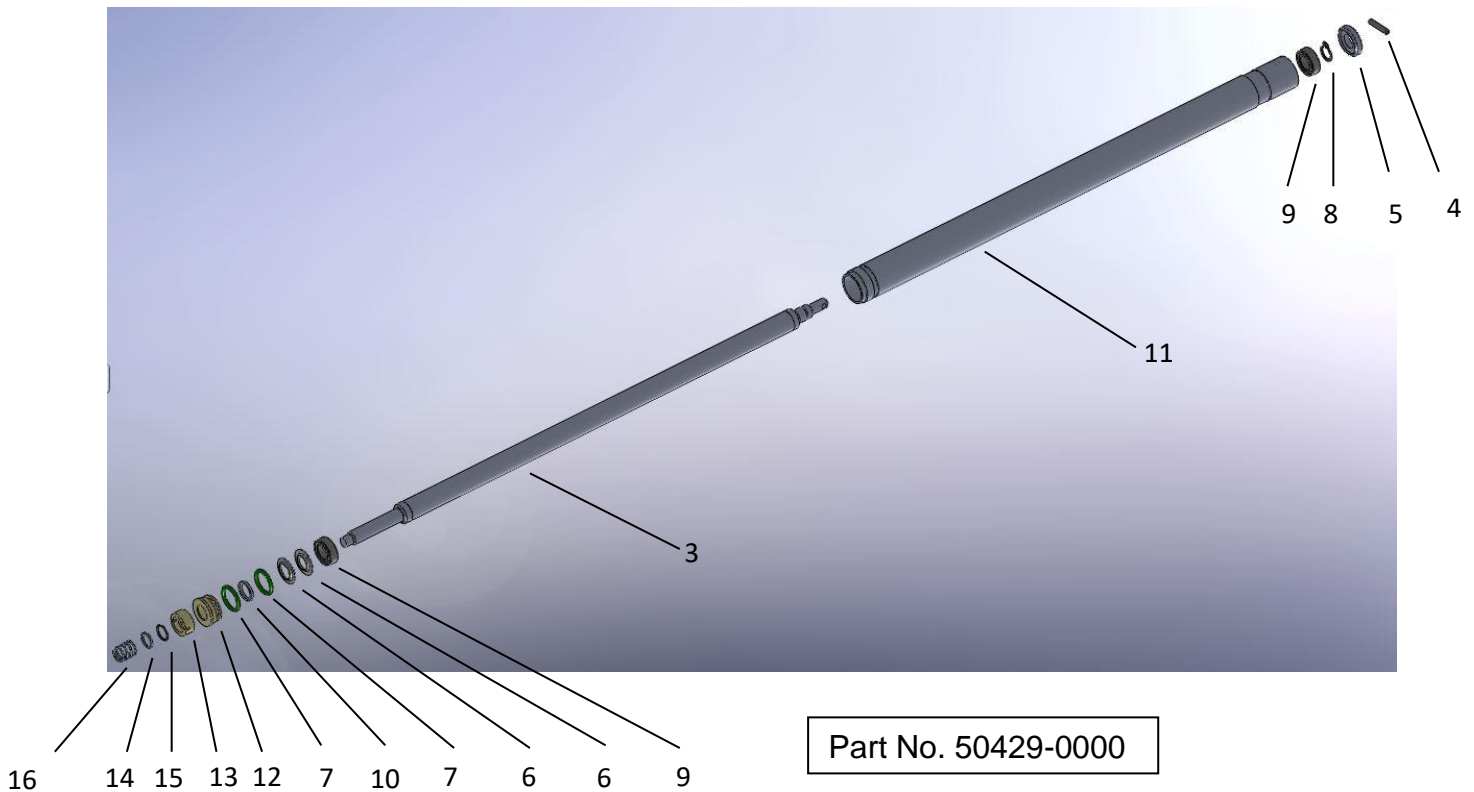

03 Rotating Shaft DK40	PN: 10429-0001	10 Spacer Disc	PN: 10415-0003
04 Drive Pin	PN: 00414-0001	11 Shaft Tube DK40	PN: 10429-0005
05 Threaded Ring	PN: 10422-0055	12 Ceramic Slip Disc	PN: 20415-0001
06 PTFE Disk	PN: 10414-0004	13 Ceramic Slip Ring	PN: 20415-0002
07 O-Ring	PN: 20423-0054	14 Retaining Disc	PN: 10415-0004
08 Retaining Ring	PN: 00422-0052	15 O-Ring	PN: 20415-0065
09 Ball Bearing	PN: 20422-0052	16 Spiral Spring	PN: 20415-0003

6.3.2 Disassembly of bearing at the bottom of the shaft G 40

The homogenizer tool comes always assembled. To disassemble hold the shaft in one hand and unscrew the stator (2) clockwise (to the right). Insert the socket wrench (B) at the top of the shaft by placing the drive pin (4) into the large slot provided by the socket wrench (B). Turn the socket wrench (B) until the two small rods at the end of the socket wrench (B) go into the two small holes located at the top of the shaft. With one hand holding the shaft and the socket wrench (B) take the rotor wrench (C) in the other hand and place the flat bar between the teeth of the rotor (1). Turn counter-clockwise (to the left). The rotor (1) now can be unscrewed easily. Now unscrew the stator (2) clockwise (to the right). The bearing now can be pulled out. The removal of the bearing is only necessary for cleaning or replacement purposes.

The bearing assembly at the bottom of the shaft consists of eleven Parts: spiral spring (16), retaining disc (14), O-ring (15), ceramic slip ring (13), ceramic slip disc (12), two O-rings (7), spacer disc (10), two PTFE discs (6) and a ball bearing (9).

6.4 Maintenance of drive unit X 1740



▲WARNING

Do not open the instrument. Repairs are only to be carried out by trained service technicians.

6.5 Maintenance homogenizing tools



▲CAUTION

The generators have sharp edges. Handle with care. Risk of injuries!

The gaskets in the homogenizing tools must be constantly monitored. In the event of leakage the suction effect of the rotating shaft can cause the medium to penetrate as far as the drive unit. If liquid emerges from the side hole at the top of the shaft tube stop work immediately and check the gaskets. The function of the generators depends on the condition of the sharp edges on the rotor and stator. These edges may be blunted very quickly in abrasive media, reducing the effectiveness of homogenizing.

7 Dismantling, Transport and Storage

7.1 Dismantling

1. Switch the unit off.
2. Disconnect it from the mains supply.
3. Remove any tubing and any other equipment around the drive unit.
4. Now you may remove the instrument from the working area.

7.2 Transport and Storage

Prior to transport:

Switch the instrument off and proceed with dismantling as described under “Dismantling”.

Place the instrument and its parts in its original packaging or another suitable container to protect it during transport. Close the packaging with adhesive tape.

Store the instrument in a dry environment. Please observe the specified conditions of the ambient (temperature and humidity).

Do not subject the instrument to mechanical shocks or vibration during transporting it.

In case you do not use the original packaging please mark the box with the following notes:

- Glass symbol (handle with care, fragile)
- Umbrella (keep dry)
- Content (list of content)
- Storage ambient:
 - Max. ambient temperature : RT to +40°C
 - Max. humidity: 80%

8 Disposal



Please dispose of used instruments and defective components at your local recycling collection point. Prior to disposal, sort according to materials: metal, glass, plastic, etc. Also be sure to dispose of the packing material in an environmental-friendly manner.

9 Warranty and Liability

The manufacturer agrees to either repair, or replace, at the manufacturer's discretion, any defects in materials or workmanship which develop within 24 months of the delivery of this product to the original user. In the event of replacement, the replacement unit will be guaranteed for the remainder of the original twenty-four (24) months period or ninety (90) days, whichever is longer.

If this product should require service, contact your local distributor or manufacturer for necessary instructions.

This guarantee will not apply if the defect or malfunction was caused by accident, neglect, unreasonable use or fitness for a particular purpose, which extend beyond the description and period set forth herein.

The manufacturer's sole obligation under this guarantee is limited to the repair or replacement of a defective product and the manufacturer shall not, in any event, be liable for any incidental or consequential damages of any kind, resulting from use or possession of the product.



▲WARNING

The user has to determine, if the instrument is suitable for his specific application. If there are any further queries, contact your local dealer or the manufacturer direct.

10 Technical Data

Dimensions: L = 410 mm
 W = 200 mm
 H = 160 mm
Weight: 6 kg
Rate of flow 80 litres per minute,

11 Repairs



▲WARNING

When returning instruments for repair that have come into contact with hazardous substances, please:

- Fill in attached "Repair Return Form"
- Provide precise information on the relevant medium
- Take protective measures to ensure the safety of our receiving and maintenance personnel
- Mark the package as appropriate for hazardous materials.

11.1 Repair Return Form

CONTACT/USER INFORMATION

Contact:	Phone No.
Fax No.	Email:
Billing:	Shipping:
Company	Company
Address	Address

INSTRUMENT INFORMATION		
Model	Serial No.	
Please describe all problems/malfunctions		
Operating Conditions (please fill in if applicable)		
Ambient Temp.	Humidity	Speed
Load	Volume	Viscosity
Temperature in °C	Sample Temperature	Operating Time
Sample Description*		

*NOTE: If the instrument was exposed to hazardous material, it must be decontaminated BEFORE returning it to Goldleaf Scientific and an MSDS for hazardous material must be included with the instrument.

RETURN SHIPPING			
UPS <input type="checkbox"/>	Air Parcel Post <input type="checkbox"/>	Collect** <input type="checkbox"/>	Other** <input type="checkbox"/>

**Your account number is required for UPS collect respectively the address and contact of your preferred forwarder if you choose any other transport means.

PACKAGING INSTRUCTIONS TO RETURN AN INSTRUMENT FOR REPAIR
--

- ✓ Remove all accessories (e.g. homogniser tools, stirring paddles) from the instrument
- ✓ Clean excess testing material off the instrument/accessory
- ✓ Include MSDS sheets for all hazardous materials used with this instrument
- ✓ Pack the instrument in its original box. If the box is not available, take care to wrap the instrument and accessories with enough material to support them.
- ✓ DO NOT send pedestal stand unless there is a problem with the upright rod, clamp or base. If there is a problem with the stand remove the upright rod from the base and individually wrap each item to avoid contact with the instrument. (Applicable for overhead stirrers and homogenisers.)
- ✓ Pack the instrument and related items in a strong box for shipping. Mark the outside of the box with handling instructions.

Example: "Handle with care" or "Fragile- Delicate Instrument" and send to:

Goldleaf Scientific 3300 Harrison st suite 2 Riverside CA 92503